

## **ADA Accessibility Guidelines: Detectable Warnings**

Please feel free to print this PDF form. The document is below. Please scroll down.

For more relevant information, please visit the Armor Tile website. This website is an excellent resource on ADA solutions, ADA regulations and requirements, truncated domes, detectable warning surface tiles and more.

You will find extensive content in the form of PDF files, Videos, Images, Word Documents, Power Point Presentations, Flash Presentations and AutoCAD Drawings on the Armor Tile website, by clicking the link below. Be sure to bookmark the Armor Tile site as a favorite.

[\*\*http://www.armor-tile.com\*\*](http://www.armor-tile.com)

# ADA Accessibility Guidelines: Detectable Warnings

## TABLE OF CONTENTS

<b>1</b>	<b>Draft Guidelines for Accessible Public Rights-of-Way (June 17, 2002).....1</b> <b>www.access-board.gov (see: Public Rights-of-Way)</b>	<b>1</b>
<b>2</b>	<b>US DOT Memorandum: Re: ADAAG &amp; Detectable Warnings ..... 2</b>	<b>2</b>
<b>3</b>	<b>ADAAG Standards: Broken Down by Section ..... 5</b> <b>www.access-board.gov (See: Publications-Facilities, Guidelines and Standards)</b> Requirements of a Detectable Warning Surface: <ul style="list-style-type: none"><li>• Sections 4.29.1-6</li></ul> Where are Detectable Warning Surfaces Required? <ul style="list-style-type: none"><li>• Curb ramps, hazardous vehicular ways and reflecting pools 4.7.7, 4.29.5 and 4.29.6</li><li>• Transit platform edges- 10.3.1(8)</li></ul>	<b>5</b>
<b>4</b>	<b>Public Rights of Way Final Report: Building a True Community..... 19</b> <b>www.access-board.gov (See: Publications-Public Rights-of-Way)</b> <ul style="list-style-type: none"><li>• Part II: Executive Summary of Detectable Warning recommended Standards: X02.5.7</li><li>• Detectable Warnings at sidewalk/street transitions: X02.4.12</li><li>• Application requirements: X02.5.7.2 (A-E)</li><li>• Specifications: X02.5.7.3 (A-E)</li></ul>	<b>19</b>
<b>5</b>	<b>Detectable Warnings: Synthesis of U.S. and International Practice ..... 37</b> <ul style="list-style-type: none"><li>• Definition and Specifications</li><li>• Geometry of Detectable Warnings</li><li>• Research on visual contrast</li></ul>	<b>37</b>
<b>6</b>	<b>Accessible Design for the Blind: Detectable Warning Surface Information..... 41</b> <b>www.accessforblind.org (See: Detectable Warnings)</b>	<b>41</b>
<b>7</b>	<b>Detectable Warnings: Compliance Check list to be used with ADAAG..... 43</b> <b>www.access-board.gov (See: Publication-Facilities, Guidance Material)</b>	<b>43</b>

## **INTRODUCTION TO DETECTABLE WARNINGS AND THE ADAAG REQUIREMENTS**

A Detectable Warning Surface is defined by ADAAG as “a standardized surface feature built in or applied to walking surfaces or other elements to warn visually impaired people of hazards on a circulation path”. Detectable Warnings incorporating truncated domes are the best indicator to alert pedestrians there is a hazard approaching in their way of travel. Due to their distinctive design, truncated domes can be identified under foot and by sound on cane contact. Color contrast is another beneficial aspect of the truncated dome, making the tile visually detectable from the surrounding surface.

The requirements outlined in ADAAG regarding Detectable Warnings to be used at hazardous vehicular ways, curb ramps and transit platform edges were enacted in 1991. Soon after in 1994, the requirements under the curb ramp section 4.7.7 and hazardous vehicular areas section 4.29.5 were suspended. The purpose of the suspension was to allow further research on the performance and detectability of various detectable warning surfaces. The suspension excluded Detectable Warnings on Transit Platform Edges.

On July 26, 2001, the Department of Justice allowed the suspension to expire. As of this date Detectable Warning Surfaces were once again a requirement on curb ramps and at hazardous vehicular ways by ADAAG. Ten years of extensive research would attest that using surfaces such as grooves, striations and exposed aggregate would not meet ADA standards because they were too similar to the surrounding surface to be properly detected. Therefore, Detectable Warnings incorporating truncated domes are the only option to make hazardous vehicular ways, curb ramps and transit platform edges truly detectable and ADA compliant.

The following information contains excerpts from both ADAAG and Public Rights of Way, all pertaining to Detectable Warnings. Also included are: US DOT Memorandum, US Synthesis, Accessible Design for the Blind and an ADAAG checklist. All outline the law requirements and specifications for Detectable Warnings and can be used as reference to meet ADA Standards.

Definitions:

**ADAAG:** Americans with Disabilities Act Accessibility Guidelines

# Draft Guidelines for Accessible Public Rights-of-Way (June 17, 2002)

## Introduction

## Background

## Discussion of Provisions

## Text of the Draft Guidelines

---

The Americans with Disabilities Act (ADA) recognizes and protects the civil rights of people with disabilities and is modeled after earlier landmark laws prohibiting discrimination on the basis of race and gender. To ensure that buildings and facilities are accessible to and usable by people with disabilities, the ADA establishes accessibility requirements for State and local government facilities, places of public accommodation, and commercial facilities. Under the ADA, the Access Board has developed and continues to maintain design guidelines for accessible buildings and facilities known as the ADA Accessibility Guidelines (ADAAG). ADAAG covers a wide variety of facilities and establishes minimum requirements for new construction and alterations.

The Board maintains a similar responsibility for accessibility guidelines under the Architectural Barriers Act (ABA). The ABA requires access to certain facilities designed, built, altered, or leased with Federal funds. Like ADAAG, the Board's ABA accessibility guidelines apply to new construction and alterations.

The Board plans to undertake rulemaking to supplement its ADA and ABA accessibility guidelines, which primarily cover facilities on sites, by adding new provisions specific to public rights-of-way. The Board's aim is to ensure that access for persons with disabilities is provided wherever a pedestrian way is newly built or altered, and that the same degree of convenience, connection, and safety afforded the public generally is available to pedestrians with disabilities. The guidelines would not require alterations to existing public rights-of-way, but would apply where a pedestrian route or facility is altered as part of a planned project to improve existing public rights-of-way.

---

## **BACKGROUND**

### **The Need for Guidelines on Public Rights-of-Way**

Local jurisdictions, and other entities covered by the ADA or ABA, must ensure that the facilities they build or alter are accessible to people with disabilities. The Board's ADA and ABA accessibility guidelines specify the minimum level of accessibility in new construction and alteration projects and serve as the basis for enforceable standards maintained by other agencies. Currently, the Board's guidelines, like the industry standards from which they derive, focus mainly on facilities on sites. While they address certain features common to public sidewalks, such as curb ramps, accessible routes, ground and floor surfaces, and bus stops and shelters, further guidance is necessary to address conditions unique to public rights-of-way. Various constraints posed by space limitations at sidewalks, roadway design practices, slope, and terrain raise valid questions on how and to what extent access can be achieved. Access for blind pedestrians at street crossings and wheelchair access to on-street parking are typical of the issues for which additional guidance is needed. In addition, new trends in roadway design, such as the growing use of traffic roundabouts, pose additional challenges to access, while various technological innovations, particularly those pertaining

to pedestrian signaling devices, offer new solutions.

The Board previously proposed guidelines for public rights-of-way under the ADA which were published for public comment in 1992 and 1994. Based on the comments received, the Board determined that it should further coordinate with the transportation industry and State and local governments before continuing its rulemaking. Consequently, the Board undertook an outreach and training program on accessible public rights-of-way. Under this program, the Board developed a series of videos, an accessibility checklist, and a design guide on accessible public rights-of-way. In addition, the Board sponsored research on tactile warnings at street crossings, accessible pedestrian signals, and traffic roundabouts. The Board has made this information widely available to the public. The interest in these materials has underscored the need for criteria for public rights-of-way that are definitive and enforceable so that local jurisdictions and others are clear on their obligations when constructing or altering streets and sidewalks.

### **Public Rights-of-Way Access Advisory Committee**

In resuming its rulemaking effort, the Board chartered an advisory committee in 1999 to develop recommendations on guidelines for accessible public rights-of-way. Use of advisory committees has become a standard practice in the Board's process for developing and updating design requirements. Through such committees, interested groups, including those representing designers, industry, and people with disabilities, play a substantive role in recommending to the Board the content of the guidelines to be developed. These committees provide significant sources of expertise while enhancing the level of consensus among stakeholders in advance of proposing a rule for public comment.

The Public Rights-of-Way Access Advisory Committee was composed of 33 members representing disability organizations, public works departments, transportation and traffic engineering groups, design professionals and civil engineers, government agencies, and standards-setting bodies. The committee coordinated its efforts with leading trade organizations represented on the committee, such as the American Association of State Highway and Transportation Officials, and federal agencies, such as the Federal Highway Administration, to ensure that its recommendations were consistent with generally accepted practice among design professionals. The committee organized several subcommittees focused on key issue areas. The subcommittee structure enabled members to continue work on a tight time schedule between meetings of the full committee and allowed for greater public participation in the process.

The advisory committee met regularly over a year's time, usually in Washington, D.C. but also in Austin and San Francisco. Its work culminated in the issuance of a report, "Building a True Community," which was submitted to the Board in January 2001. The committee's report provides criteria for the construction or alteration of public rights-of-way that reflects the broad spectrum of expertise represented by committee members. The report follows a "toolbox" approach to the establishment of guidelines designed to facilitate implementation and to promote an understanding of the needs of all users of public rights-of-ways. The report comprehensively covers the various components of public streets and sidewalks and provides criteria for sidewalks, street fixtures and furnishings, street crossings, vehicular ways, parking, and other components of public rights-of-way. In addition, the report includes advisory notes, figures, and discussion of issues that merit further study or special attention in the Board's rulemaking.

### **Release of Draft Guidelines**

An ad hoc group of Board members proceeded to review the committee's report in depth and to craft a set of draft guidelines based on the committee's recommendations. The draft guidelines depart

from the advisory committee's report in several areas, which are detailed in the following discussion. Because of these differences, the Board is making an advance draft of the guidelines available for comment by the public, including industry groups, State and local governments, and advisory committee members. The Board also seeks information and feedback, including usability and cost data. Instructions on providing comment in writing or at an information meeting to be held in Portland, Oregon, in October, are provided in a [notice](#) the Board published on the release of the draft guidelines.

### **Rulemaking Process**

The Board is making these draft guidelines available for public review and comment to seek information and input for its use in developing a proposed rule. The proposed rule will provide another opportunity for public comment on the guidelines. The Board will then proceed to finalize the guidelines based on public comments received in response to the proposed rule. The Board's guidelines serve as the basis for enforceable standards maintained by other agencies under the ADA and the ABA. The Department of Justice and the Department of Transportation maintain standards based on the Board's guidelines that apply to facilities covered by the ADA. Design standards for federally funded facilities covered by the ABA are maintained by the Department of Defense, the Department of Housing and Urban Development, the General Services Administration, and the U.S. Postal Service. These enforceable standards must be consistent with the Board's guidelines.

### **Relationship to ADA and ABA Accessibility Guidelines**

Currently, the Board is completing an update of ADAAG, the first comprehensive revision of the document since its publication in 1991. The revised ADAAG features a new format and numbering system and a host of updated scoping and technical provisions. The Board is updating its ABA Accessibility Guidelines along similar lines so that both of the documents are more consistent. The Board released a draft of the final ADA and ABA guidelines last April.

The draft guidelines for public rights-of-way are being developed as a supplement to the ADA and ABA guidelines and not as a stand-alone document. As such, they will ultimately comprise a new chapter on public rights-of-way. The Board has revised recommendations from the advisory committee in preparing these draft guidelines in order to facilitate their incorporation into the ADA and ABA guidelines. The draft guidelines presented here support the new format and structure of those documents. In addition, various provisions of this draft refer to provisions in the ADA and ABA guidelines to minimize redundancy. For simplicity, the following discussion refers to the draft final ADA and ABA guidelines released in April as "ADAAG," an acronym that has wide currency.

---

## **DRAFT GUIDELINES FOR PUBLIC RIGHTS-OF-WAY: DISCUSSION OF PROVISIONS**

The proposed draft is formatted as a separate chapter, 11 Public Rights-of-Way, to be integrated into ADAAG. This chapter has a general section (1101), a scoping section, which indicates what is covered (1102), and technical sections addressing various elements of public rights-of-ways (1103 to 1111). Figures and advisory notes provided in the advisory committee's report are not included in this draft, but will be included in the proposed rule.

on walls or posts with leading edges above the standard sweep of canes (27 inches) and below the standard head room clearance (80 inches) would be limited to a 4 inch protrusion.

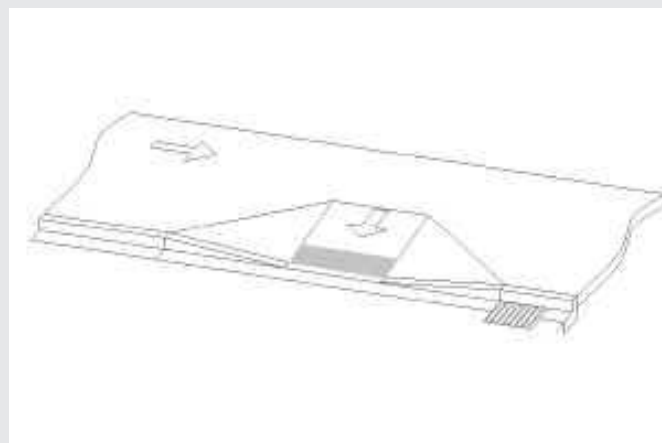
### **Curb Ramps and Blended Transitions (1102.6, 1104)**

Curb ramps or blended transitions would be required to connect pedestrian access routes to street crossings and to be located within the width of each crosswalk. Generally, this would require two separate curb ramps at a corner instead of a single ramp that opens diagonally onto an intersection. The advisory committee strongly discouraged single installations where possible for several reasons. Single ramps can misdirect blind pedestrians who use the slope of curb ramps as a cue. They can increase crossing times for persons who use wheeled mobility aids and can place users into oncoming traffic at small radius corners where it is difficult to provide landing space at the bottom that is wholly within marked crossings. Also, drivers may not be as alert to persons crossing at the apex of a corner. On the other hand, the advisory committee recognized that providing two separate compliant curb ramps may not always be practicable, particularly in alterations, due to storm drain inlets, utility poles, and other constraints.

The draft guidelines provide technical criteria for perpendicular curb ramps, parallel curb ramps, and blended transitions. Perpendicular curb ramps, the most common type, have a running slope that cuts through a curb or meets the gutter grade break at right angles. Parallel curb ramps have a running slope that is in line with the direction of sidewalk travel. Blended transitions can be achieved by depressing the entire curb radius to street level or, less commonly, raising street crossings to sidewalk level, which can serve as a traffic calming strategy by creating a "speed table" at intersections. Various combinations of these different types of ramps and transitions can be used. For example, parallel ramps can be used for a portion of a curb level change in conjunction with a perpendicular ramp or a blended transition. The draft guidelines include requirements specific to each of these elements as well as criteria common to all of them.

#### *Perpendicular Curb Ramps (1104.2.1)*

Consistent with ADAAG, curb ramps must have a maximum running slope of 1:12. The draft guidelines specify a minimum running slope of 1:48 for perpendicular ramps (and parallel ramps) in order to distinguish them from blended transitions, which cannot have a slope of more than 1:48. Requirements specific to perpendicular curb ramps address the cross slope (1:48 maximum), level landings at the top (48 by 48 inches minimum), and side flares (1:10 maximum slope). Sidewalks are permitted to follow the running grade of the adjoining roadway, which

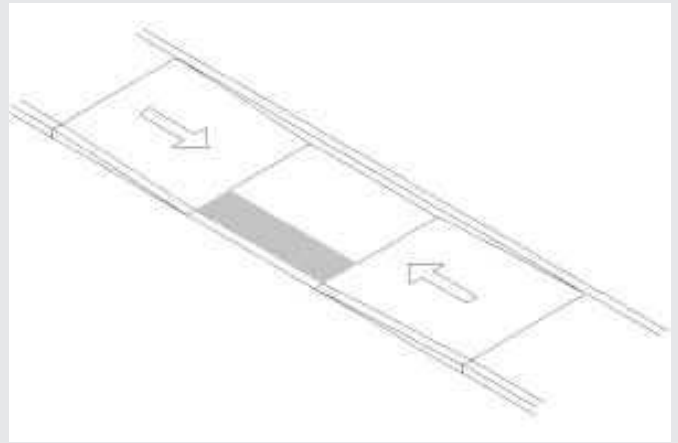


determines the cross slope of perpendicular ramps and landings at mid-block crossings. Exceptions are provided for ramps located at mid-block crossings that permit the cross slope of the ramp and landing to be greater than 1:48 so that the ramp can transition smoothly to the street crossing. Otherwise, maintaining a 1:48 cross slope at streets with a steeper grade would result in a warped transition from the ramp to the road, which is problematic for wheelchair maneuvering.

#### *Parallel Curb Ramps (1104.2.2)*

### *Parallel Curb Ramps (1104.2.2)*

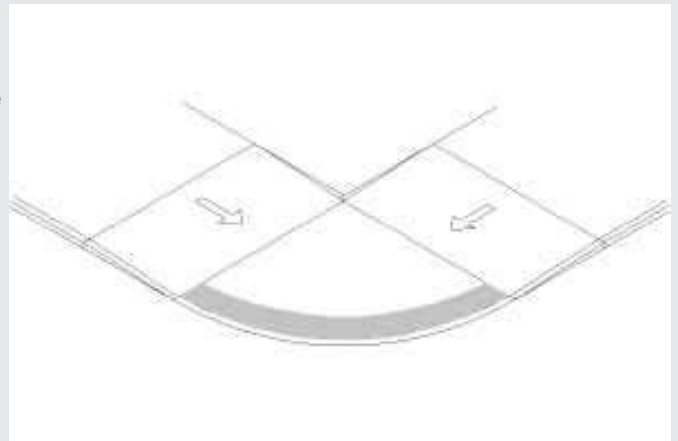
Parallel ramps are especially suited to narrow rights-of-way where there is insufficient space for the top landing of a perpendicular curb ramp. In this case, the bottom landing usually serves as the direct connection to the street crossing. Criteria for parallel curb ramps address the running slope (1:12 maximum and 1:48 minimum), cross slope (1:48 maximum), level landings at the bottom (at least 48 by 48 inches), and barriers at drop-offs. The running slope of parallel curb ramps will be affected by the slope of the sidewalk, which is permitted to be as steep as the adjacent roadway.



Thus, a maximum slope of 1:12 may not be achievable due to the road grade. In recognition of this, an exception limits the required length of a parallel ramp to 15 feet, regardless of the slope. The landing required at the bottom of the ramp is not permitted to slope more than 1:48 in any direction, but an exception is also provided for mid-block crossings where compliance with this specification may be affected by the roadway grade. Where parallel curb ramps do not span the full width of a sidewalk, a barrier is required along the drop-off created by the ramp to prevent tripping hazards.

### *Blended Transitions (1104.2.3)*

Blended transitions are to have slopes parallel and perpendicular to the curb no greater than 1:48. Transitions with a slope greater than 1:48 are to be treated as a curb ramp.



### *Common Elements (1104.3)*

Curb ramps and blended transitions would be subject to requirements for clear width (48 inches minimum), detectable warnings, surfaces, grade breaks, changes in level, counter slopes, and clear space.

### *Detectable Warnings (1104.3.2)*

Detectable warnings provide a distinctive surface of truncated domes detectable by cane or underfoot to alert people with vision impairments of the transition to vehicular ways. These warnings compensate for the sloped surfaces of curb ramps which remove a tactile cue provided by curb faces. ADAAG, as originally published in 1991, contained a requirement for detectable warnings on the surface of curb ramps and other locations where pedestrian ways blend with vehicular ways without tactile cues. This requirement was temporarily suspended due to concerns raised about the specifications, the availability of complying products, maintenance, usefulness, safety, and the need for further study. The suspension expired in July 2001.

The advisory committee considered the issue at length and recommended that the draft guidelines require detectable warnings according to revised specifications. The Board agrees with the committee's recommendation and has included a requirement for a detectable warning surface 2 feet deep where the ramp, landing, or blended transition connects to a crosswalk. Since detectable warnings are intended to replace the cue otherwise provided by a curb drop-off, they would be required to span the entire area where the curb drop-off is absent. This is especially important for blended transitions, where there is no slope to help detect the presence of a ramp.

The advisory committee deliberated on whether to require detectable warnings at all curb ramps and blended transitions or only those which were the least distinguishable. One organization represented on the committee suggested that detectable warnings be required only where the ramp slope was 1:15 or less. The Board seeks comment on this issue as well as any research that supports slopes of 1:15 or steeper being sufficiently detectable by persons with vision impairments.

The technical specifications for detectable warnings are discussed below in **section 1108**.

#### *Other Requirements for Curb Ramps and Blended Transitions (1104.3.3 - 1104.3.7)*

Other technical requirements for curb ramps and blended transitions would:

- require compliance with specifications in ADAAG section 302 covering surface firmness, stability, and slip-resistance;
- prohibit the placement of gratings, storm drain, utility and sewer access covers, and similar fixtures on ramps, landings, transitions and portions of the gutter within the pedestrian access route;
- prohibit grade breaks on ramp runs, blended transitions, landings, and gutter areas within the pedestrian access route;
- require a flush transition at permitted grade breaks, such as at the top and bottom of ramp runs;
- prohibit any vertical changes in level on curb ramps, landings and gutter areas within the pedestrian access route;
- limit the counter slope of the gutter area or street at the foot of the curb ramp or blended transition to be 1:20 maximum (the advisory committee had recommended that the sum of the slope of the ramp and gutter or street be 11 percent or less, but the Board believes that the 1:20 specification, which is consistent with ADAAG, will be easier to understand and enforce); and
- require clear space at least 48 by 48 inches, located beyond the curb line and wholly within crosswalks and out of the parallel traffic travel lane.

#### **Pedestrian Signs (1102.7)**

Signs provided for pedestrian use would be subject to certain ADAAG specifications for visual legibility. These requirements would not apply to traffic and street signs intended for vehicle operators, which are covered by the MUTCD. Provisions are included for bus route identification signs, informational signs, and warning signs. Specifications in ADAAG 703.5 for visual characters are referenced. This section of ADAAG covers finish and contrast, style, the proportions and height of characters, sign height, stroke thickness, and character and line spacing.

##### *Bus Route Identification (1102.7.1)*

Bus route identification signs would be subject to the visual character requirements, except those for character height (which would apply only to the maximum extent practicable) and sign height. This requirement would not apply to bus schedules, timetables, or maps. This provision is consistent with existing ADAAG provisions for bus stops and shelters (section 810.4). In addition, the draft guidelines would require route identification signs located at bus shelters to be tactile and provide information in raised and Braille characters according to specifications in ADAAG (section 703.2). Raised characters are to have rounded corners. An exception permits certain types of audible signs to substitute for tactile signage.

##### *Informational Signs and Warning Signs (1102.7.2)*

ADAAG specifications for visual legibility would also apply to informational signs and warning signs

### **Detectable Warning Surfaces (1108)**

Pedestrian street crossings, including, curb ramps and blended transitions (1104.3.2), certain median and refuge islands (1105.4.2), and rail lines (1103.7) are required to have detectable warnings for persons with vision impairments. These surfaces feature a distinctive pattern of raised domes to provide a tactile cue detectable by cane or underfoot at the boundary between pedestrian and vehicular routes.

Specifications in section 1108 address the area that these warnings are to cover at required locations. The Board has revised the technical criteria for detectable warnings in order to facilitate compliance and to accommodate existing detectable warning products that have been deemed to provide an equivalent level of accessibility. The revised specifications are also responsive to concerns that had been raised about the impact of the truncated dome surface on wheelchair maneuvering. The Board believes that the revised specifications, which permit wider dome spacing, an in-line grid pattern, and smaller surface coverage at curb ramps (24 inches instead of the full ramp length) will further minimize disruptions or hazards to wheelchair traffic.

### **Stairs (1102.10)**

The draft guidelines apply requirements in ADAAG section 504 to stairs in public rights-of-way. These ADAAG specifications address tread depth and riser height, nosings, handrail and surface requirements, and prohibit open risers. The draft guidelines also include a new requirement for contrasting color across the nosing of stairs in the public right-of-way. This latter provision was recommended by the advisory committee because of the difficulty persons with low vision have in perceiving steps under the variable lighting conditions in public rights-of-ways.

### **Handrails (1102.11)**

Consistent with the revised ADAAG, handrails, where provided, would be subject to ADAAG section 505, which provides specifications for height, knuckle clearance, gripping surface, cross section, surfaces, fittings, and extensions.

### **Vertical Access (1102.12)**

Where elevators or lifts are provided in public rights-of-ways, the draft guidelines would apply specifications in ADAAG for passenger elevators (section 407), limited-use/ limited-application elevators (section 408), and platform lifts (section 410). Elevators are not required by these guidelines except at certain pedestrian overpasses and underpasses with elevation changes greater than 60 inches.

### **Bus Stops (1102.13)**

ADAAG contains requirements for bus boarding and alighting areas and bus shelters in section 810.2 and 810.3. These requirements address bus stop surfacing, dimensions, connections to accessible routes, slope, and wheelchair space within bus shelters. The draft guidelines would apply these requirements to bus stops and shelters provided in public rights-of-way.

### **On-Street Parking (1102.14, 1109)**

A key issue addressed in the guidelines is how to provide access to on-street parking. Current ADAAG scoping and technical requirements are specific to parking lots and facilities on sites. Over the years, the Board has received many inquiries on how they can be applied to on-street spaces. The draft guidelines would require access to at least one parking space on each block face. The advisory committee recommended applying ADAAG requirements in section 208 for parking lots and facilities which uses a sliding scale based on the total number of spaces provided. This scale starts

---

---

## Text of the Draft Guidelines for Accessible Public Rights-of-Way

**1101 Application and Administration** (referenced standards and defined terms)

**1102 Scoping Requirements**

**1103 Pedestrian Access Route**

**1104 Curb Ramps and Blended Transitions**

**1105 Pedestrian Crossings**

**1106 Accessible Pedestrian Signal Systems**

**1107 Street Furniture**

**1108 Detectable Warning Surfaces**

**1109 On-Street Parking**

**1110 Call Boxes**

**1111 Alternate Circulation Path**

---

### 1101 Application and Administration

**1101.1 General.** For the purposes of these requirements, the terms listed in section 1101.3 shall have the indicated meaning.

#### 1101.2 Referenced Standards.

**1101.2.1 MUTCD.** Copies of the referenced standards may be obtained on-line from the Federal Highway Administration at <http://mutcd.fhwa.dot.gov>.

MUTCD 2000-Millennium Edition Manual on Uniform Traffic Control Devices.

#### 1101.3 Defined Terms.

**Accessible Pedestrian Signal.** A device that communicates information about the pedestrian WALK phase in non-visual format.

**Accessible Route.** A continuous, unobstructed path that complies with Chapter 4.

**Channelizing Island.** Curbed or painted area outside the vehicular path that is provided to separate and direct traffic movement, which also may serve as a refuge for pedestrians.

**Cross Slope.** The slope that is perpendicular to the direction of travel. This is usually called superelevation on curves in the public right-of-way (see superelevation).

**1103.7 Surface Gaps at Rail Crossings.** Where the pedestrian access route crosses rail systems at grade, the horizontal gap at the inner edge of each rail shall be constructed to the minimum dimension necessary to allow passage of railroad car wheel flanges and shall not exceed 2-½ inches (64 mm).

**EXCEPTION:** On tracks that carry freight, a maximum horizontal gap of 3 inch (75 mm) shall be permitted.

**1103.7.1 Detectable Warnings.** Where rail systems cross pedestrian facilities that are not shared with vehicular ways, a detectable warning shall be provided in compliance with [1108](#).

**1103.8 Changes in Level.** Changes in level shall comply with 303. Changes in level shall be separated horizontally 30 inches (760 mm) minimum.

**EXCEPTION:** The horizontal separation requirement shall not apply to detectable warnings.

**1103.8.1 Rail Crossings.** Where the pedestrian access route crosses rail systems at grade, the surface of the pedestrian access route shall be level and flush with the top of the rail at the outer edge and between the rails.

---

## 1104 Curb Ramps and Blended Transitions

**1104.1 General.** Curb ramps and blended transitions shall comply with 1104.

**1104.2 Types.** Perpendicular curb ramps shall comply with 1104.2.1 and 1104.3; parallel curb ramps shall comply with 1104.2.2 and 1104.3; blended transitions shall comply with 1104.2.3 and 1104.3.

**1104.2.1 Perpendicular Curb Ramps.** Perpendicular curb ramps shall comply with 1104.2.1, and shall have a running slope that cuts through the curb at right angles or

**1104.3 Common Elements.** Curb ramps and blended transitions shall comply with 1104.3.

**1104.3.1 Width.** The clear width of landings, blended transitions, and curb ramps, excluding flares, shall be 48 inches (1220 mm) minimum.

**1104.3.2 Detectable Warnings.** Detectable warning surfaces complying with [1108](#) shall be provided, where a curb ramp, landing, or blended transition connects to a crosswalk.

**1104.3.3 Surfaces.** Surfaces of curb ramps, blended transitions, and landings shall comply with 302. Gratings, access covers, and other appurtenances shall not be located on curb ramps, landings, blended transitions, and gutter areas within the pedestrian access route.

distance used in calculating pedestrian signal phase timing shall include the entire length of the crosswalk plus the length of the curb ramp.

**1105.4 Medians and Pedestrian Refuge Islands.** Medians and pedestrian refuge islands in crosswalks shall comply with 1105.4 and shall be cut through level with the street or have curb ramps complying with **1104** and shall contain a pedestrian access route complying with **1103**. Where the cut-through connects to the street, edges of the cut-through shall be aligned with the direction of the crosswalk for a length of 24 inches (610 mm) minimum.

**1105.4.1 Length.** Where signal timing is inadequate for full crossing of all traffic lanes or where the crossing is not signalized, cut-through medians and pedestrian refuge islands shall be 72 inches (1830 mm) minimum in length in the direction of pedestrian travel.

**1105.4.2 Detectable Warnings.** Medians and refuge islands shall have detectable warnings complying with **1108**. Detectable warnings at cut-through islands shall be separated by a 24 inch (610 mm) minimum length of walkway without detectable warnings.

**EXCEPTION:** Detectable warnings shall not be required on cut-through islands where the crossing is controlled by signals and is timed for full crossing.

**1105.5 Pedestrian Overpasses and Underpasses.** Pedestrian overpasses and underpasses shall comply with 1105.5.

**1105.5.1 Pedestrian Access Route.** Pedestrian overpasses and underpasses shall contain a pedestrian access route complying with **1103**.

**1105.5.2 Running Slope.** The running slope shall not exceed 1:20 maximum.

**1105.5.3 Approach.** Where the approach exceeds 1:20, the approach shall be a ramp 48 inches (1220 mm) minimum in width and shall comply with 405. Where the rise of a ramped approach exceeds 60 inches (1525 mm), an elevator complying with 407, or a limited- use/limited-application elevator complying with 408 shall be provided.

**1105.5.4 Stairs.** Stairs shall comply with 504.

**1105.5.5 Escalators.** Escalators shall comply with 810.9.

**1105.6 Roundabouts.** Where pedestrian crosswalks and pedestrian facilities are provided at roundabouts, they shall comply with 1105.6.

**1105.6.1 Separation.** Continuous barriers shall be provided along the street side of the sidewalk where pedestrian crossing is prohibited. Where railings are used, they shall have a bottom rail 15 inches (380 mm) maximum above the pedestrian access route.

**1105.6.2 Signals.** A pedestrian activated traffic signal complying with **1106** shall be

## 1108 Detectable Warning Surfaces

**1108.1 General.** Detectable warnings shall consist of a surface of truncated domes aligned in a square grid pattern and shall comply with 1108.

**1108.1.1 Dome Size.** Truncated domes in a detectable warning surface shall have a base diameter of 0.9 inches (23 mm) minimum to 1.4 inches (36 mm) maximum, a top diameter of 50% of the base diameter minimum to 65% of the base diameter maximum, and a height of 0.2 inches (5 mm).

**1108.1.2 Dome Spacing.** Truncated domes in a detectable warning surface shall have a center-to-center spacing of 1.6 inches (41 mm) minimum and 2.4 inches (61 mm) maximum, and a base-to-base spacing of 0.65 inches (16 mm) minimum, measured between the most adjacent domes on square grid.

**1108.1.3 Contrast.** Detectable warning surfaces shall contrast visually with adjacent walking surfaces either light-on-dark, or dark-on-light.

**1108.1.4 Size.** Detectable warning surfaces shall extend 24 inches (610 mm) minimum in the direction of travel and the full width of the curb ramp, landing, or blended transition.

### 1108.2 Location.

**1108.2.1 Curb Ramps and Blended Transitions.** The detectable warning surface shall be located so that the edge nearest the curb line is 6 inches (150 mm) minimum and 8 inches (205 mm) maximum from the curb line.

**1108.2.2 Rail Crossings.** The detectable warning surface shall be located so that the edge nearest the rail crossing is 6 inches (150 mm) minimum and 8 inches (205 mm) maximum from the vehicle dynamic envelope.

**1108.2.3 Platform Edges.** Detectable warning surfaces at platform boarding edges shall be 24 inches (610 mm) wide and shall extend the full length of the platform.

---

## 1109 On-Street Parking

**1109.1 General.** Car and van on-street parking spaces shall comply with 1109.

**1109.2 Parallel Parking Spaces.** An access aisle at least 60 inches (1525 mm) wide shall be provided at street level the full length of the parking space. The access aisle shall connect to a pedestrian access route serving the space. The access aisle shall not encroach on the vehicular travel lane.



U.S. Department  
of Transportation

**Federal Highway  
Administration**

# Memorandum

Subject: **INFORMATION:** ADAAG Detectable Warnings  
(Truncated Domes)

Date: May 6, 2002

From: Dwight A. Horne *Dwight A. Horne*  
Director, Office of Program Administration

Reply to  
Attn. of: HIPA-20

To: Resource Center Managers  
Division Administrators  
Federal Lands Highway Division Engineers

Recently a number of questions have been raised by people from various agencies concerning the use of detectable warnings, specifically truncated domes, when constructing or altering curb ramps. Truncated domes are the standard design requirement for detectable warnings for determining the boundary between the sidewalk and street by people with visual disabilities.

The Department of Justice (DOJ) is the lead agency that oversees the Americans with Disabilities Act (ADA)(1990). The U.S. Access Board develops the minimum design standards for complying with the ADA. The Department of Transportation is a designated agency responsible for enforcing the standards and implementing regulations of the ADA's Title II (State and Local Government Services). The Federal Highway Administration (FHWA) is the enforcement authority for overseeing pedestrian discrimination issues under the Title II implementing regulations.

Detectable warnings were required in 1991 by the Americans with Disabilities Act Accessible Guideline (ADAAG) (regulatory standards) for hazardous vehicular ways, transit platform edges, and curb ramps. A suspension was placed on requiring detectable warnings at curb ramps and hazardous vehicular ways, but not for transit platform edges. The reason for the suspension was to conduct research on the performance of their detectability. The DOJ continued the suspension through July 26, 2001, which allowed 10 years for conducting research. The research determined that other designs used in place of truncated domes such as grooves, striations, and exposed aggregate, were not detectable in the sidewalk and roadway environment because of the similarities to other surface textures and defects. Truncated domes have a unique design that can be detected underfoot and with a cane, and other surfaces are not considered ADA equivalent and therefore do not comply with the ADA requirements.

The DOJ had the option of allowing the suspension to expire on July 26, 2001 or publish a Federal Register Notice to continue the suspension. They decided to let the suspension expire. Consequently, since July 26, 2001 detectable warnings are again required. FHWA is obligated to enforce the requirements, and State and local governments are required to apply the minimum design standards when constructing and altering pedestrian facilities, though we encourage higher than minimum standards where possible.

The original ADA design standard for truncated domes is found in ADAAG (4.29.2). After the research was conducted, a new design recommendation was made for the dimension and placement of the domes on curb ramps. Both FHWA and the U.S. Access Board are encouraging the use of the new design over the original. Information on the recommended design and other useful information are included in the attachment.

Attachment

## Information on Detectable Warnings (truncated domes)

Detectable warnings are an Americans with Disabilities Act (ADA) requirement in the current Americans with Disabilities Act Accessibility Guidelines (ADAAG) for the use of detecting the boundary between the sidewalk and the street. The original requirement in ADAAG was suspended for a time to conduct further research. Research was conducted, and the suspension of the requirement was lifted on July 26, 2001, and are now required when constructing and altering curb ramps. Truncated domes are the only detectable warnings allowed by ADAAG. Grooves, exposed aggregate, and other designs intended for use as detectable warning are too similar to pavement textures, cracks and joints and are not considered equivalent facilitation. Truncated domes are a unique design and have proven to be the most detectable surface.

### **Where to find information on detectable warnings:**

*Where to find the regulation on the suspension and requirement:*

The US Department of Justice website, [www.usdoj.gov/crt/ada/detwarn.htm](http://www.usdoj.gov/crt/ada/detwarn.htm), or visit the US Access Board's website, [www.access-board.gov](http://www.access-board.gov), click on "publications," go to "facilities," go to "Detectable Warnings: Final Rule"

*Where to find the design and application requirement in ADAAG:*

Visit the US Access Board's website, [www.access-board.gov](http://www.access-board.gov), click on "publications," go to "facilities," go to "ADA Accessibility Guidelines (ADAAG)" –the provision is in 4.7.7 under Curb Ramps

*Where to find technical information and a list of manufactures:*

Visit the US Access Board's website, [www.access-board.gov](http://www.access-board.gov), click on "publications," go to "Public Rights-of-Way," go to *Detectable Warnings: Synthesis of US and International Practice*

*Where to find the recommended design for curb ramps:*

Visit the US Access Board's website, [www.access-board.gov](http://www.access-board.gov), click on "publications," go to "Public Rights-of-Way," go to *Building A True Community: Accessible Public Rights-of-Ways*, sections X02.5.6.2 through X02.5.7.3. After a number of years of research there is a new recommended design for detectable warning/truncated dome. Both the US Access Board and FHWA recommend the new design pattern and application over the original ADAAG design. FHWA's *Designing Sidewalks and Trails for Access, Part II, Best Practices Design Guide* has comparable information to the *Building A True Community* report. At the time the FHWA *Designing Sidewalks and Trails for Access*, went to print, the suspension had not been lifted, so the text in Chapter 6 does not mention that detectable warnings are required.

# **Americans with Disabilities Act (ADA)**

## **Accessibility Guidelines for Buildings and Facilities**

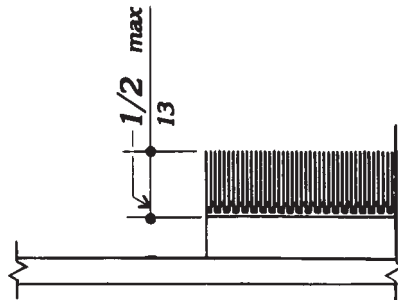
**U.S. Architectural and Transportation Barriers  
Compliance Board (Access Board)  
1331 F Street, N.W., Suite 1000  
Washington, D.C. 20004-1111  
(202) 272-0080  
(202) 272-0082 TTY  
(202) 272-0081 FAX**

**ADA ACCESSIBILITY GUIDELINES  
FOR BUILDINGS AND FACILITIES  
TABLE OF CONTENTS**

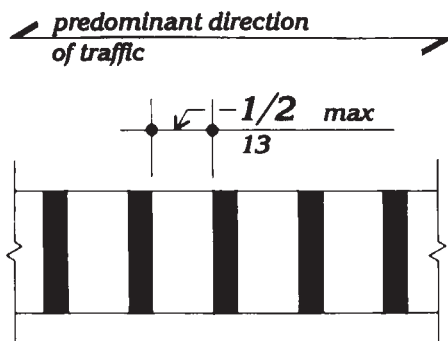
<b>1. PURPOSE</b> .....	<b>1</b>
<b>2. GENERAL</b> .....	<b>1</b>
2.1 Provisions for Adults and Children .....	1
2.2 Equivalent Facilitation .....	1
2.3 Incorporation by Reference .....	1
<b>3. MISCELLANEOUS INSTRUCTIONS AND DEFINITIONS</b> .....	<b>2</b>
3.1 Graphic Conventions .....	2
3.2 Dimensional Tolerances .....	2
3.3 Notes .....	2
3.4 General Terminology .....	2
3.5 Definitions .....	3
<b>4. ACCESSIBLE ELEMENTS AND SPACES: SCOPE AND TECHNICAL REQUIREMENTS</b> .....	<b>6</b>
4.1 Minimum Requirements .....	6
4.1.1 Application .....	6
4.1.2 Accessible Sites and Exterior Facilities: New Construction .....	7
4.1.3 Accessible Buildings: New Construction .....	9
4.1.4 (Reserved) .....	14
4.1.5 Accessible Buildings: Additions .....	14
4.1.6 Accessible Buildings: Alterations .....	14
4.1.7 Accessible Buildings: Historic Preservation .....	17
4.2 Space Allowance and Reach Ranges .....	18
4.3 Accessible Route .....	19
4.4 Protruding Objects .....	25
4.5 Ground and Floor Surfaces .....	26
4.6 Parking and Passenger Loading Zones .....	28
4.7 Curb Ramps .....	29
4.8 Ramps .....	31
4.9 Stairs .....	34
4.10 Elevators .....	34
4.11 Platform Lifts (Wheelchair Lifts) .....	40
4.12 Windows .....	40
4.13 Doors .....	40
4.14 Entrances .....	44
4.15 Drinking Fountains and Water Coolers .....	44

4.16	Water Closets . . . . .	45
4.17	Toilet Stalls . . . . .	46
4.18	Urinals . . . . .	49
4.19	Lavatories and Mirrors . . . . .	49
4.20	Bathtubs . . . . .	50
4.21	Shower Stalls . . . . .	50
4.22	Toilet Rooms . . . . .	51
4.23	Bathrooms, Bathing Facilities, and Shower Rooms . . . . .	53
4.24	Sinks . . . . .	55
4.25	Storage . . . . .	55
4.26	Handrails, Grab Bars, and Tub and Shower Seats . . . . .	56
4.27	Controls and Operating Mechanisms . . . . .	56
4.28	Alarms . . . . .	58
4.29	Detectable Warnings . . . . .	58
4.30	Signage . . . . .	59
4.31	Telephones . . . . .	60
4.32	Fixed or Built-in Seating and Tables . . . . .	62
4.33	Assembly Areas . . . . .	64
4.34	Automated Teller Machines . . . . .	64
4.35	Dressing, Fitting, and Locker Rooms . . . . .	65
4.36	Saunas and Steam Rooms . . . . .	65
4.37	Benches . . . . .	66
<b>5.</b>	<b>RESTAURANTS AND CAFETERIAS . . . . .</b>	<b>66</b>
<b>6.</b>	<b>MEDICAL CARE FACILITIES . . . . .</b>	<b>68</b>
<b>7.</b>	<b>BUSINESS, MERCANTILE AND CIVIC . . . . .</b>	<b>69</b>
<b>8.</b>	<b>LIBRARIES . . . . .</b>	<b>70</b>
<b>9.</b>	<b>ACCESSIBLE TRANSIENT LODGING . . . . .</b>	<b>71</b>
<b>10.</b>	<b>TRANSPORTATION FACILITIES . . . . .</b>	<b>75</b>
<b>11.</b>	<b>JUDICIAL, LEGISLATIVE AND REGULATORY FACILITIES . . . . .</b>	<b>80</b>
<b>12.</b>	<b>DETENTION AND CORRECTIONAL FACILITIES . . . . .</b>	<b>82</b>
<b>13.</b>	<b>RESIDENTIAL HOUSING (Reserved) . . . . .</b>	<b>84</b>
<b>14.</b>	<b>PUBLIC RIGHTS-OF-WAY (Reserved) . . . . .</b>	<b>84</b>
<b>15.</b>	<b>RECREATION FACILITIES . . . . .</b>	<b>84</b>
<b>APPENDIX</b>	<b>. . . . .</b>	<b>A1</b>

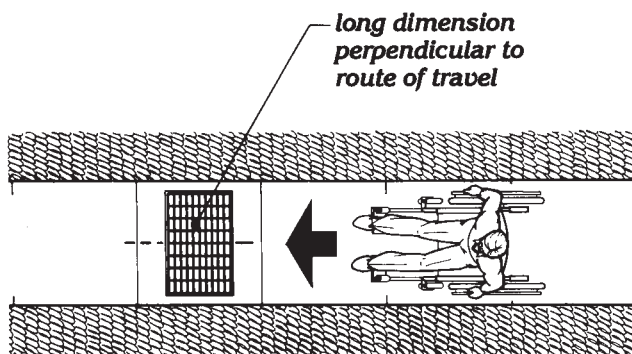
## 4.7 Curb Ramps.



**Fig. 8 (f)**  
**Carpet Pile Thickness**



**Fig. 8 (g)**  
**Gratings**



**Fig. 8 (h)**  
**Grating Orientation**

**4.6.3\* Parking Spaces.** Accessible parking spaces shall be at least 96 in (2440 mm) wide. Parking access aisles shall be part of an accessible route to the building or facility entrance and shall comply with 4.3. Two accessible parking spaces may share a common access aisle (see Fig. 9). Parked vehicle overhangs shall not reduce the clear width of an accessible route. Parking spaces and access aisles shall be level with surface slopes not exceeding 1:50 (2%) in all directions.

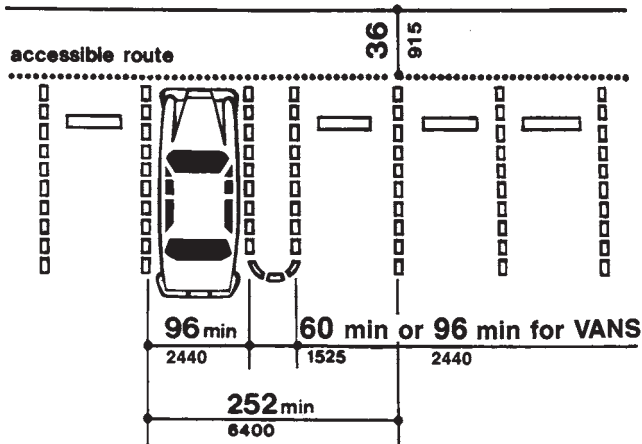
**4.6.4\* Signage.** Accessible parking spaces shall be designated as reserved by a sign showing the symbol of accessibility (see 4.30.7). Spaces complying with 4.1.2(5)(b) shall have an additional sign "Van-Accessible" mounted below the symbol of accessibility. Such signs shall be located so they cannot be obscured by a vehicle parked in the space.

**4.6.5\* Vertical Clearance.** Provide minimum vertical clearance of 114 in (2895 mm) at accessible passenger loading zones and along at least one vehicle access route to such areas from site entrance(s) and exit(s). At parking spaces complying with 4.1.2(5)(b), provide minimum vertical clearance of 98 in (2490 mm) at the parking space and along at least one vehicle access route to such spaces from site entrance(s) and exit(s).

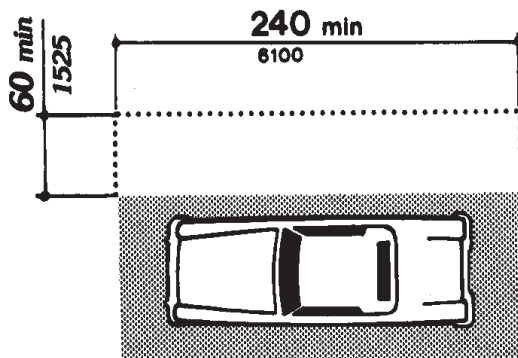
**4.6.6 Passenger Loading Zones.** Passenger loading zones shall provide an access aisle at least 60 in (1525 mm) wide and 20 ft (240 in)(6100 mm) long adjacent and parallel to the vehicle pull-up space (see Fig. 10). If there are curbs between the access aisle and the vehicle pull-up space, then a curb ramp complying with 4.7 shall be provided. Vehicle standing spaces and access aisles shall be level with surface slopes not exceeding 1:50 (2%) in all directions.

## 4.7 Curb Ramps.

**4.7.1 Location.** Curb ramps complying with 4.7 shall be provided wherever an accessible route crosses a curb.



**Fig. 9**  
**Dimensions of Parking Space**



**Fig. 10**  
**Access Aisle at Passenger Loading Zones**

**4.7.2 Slope.** Slopes of curb ramps shall comply with 4.8.2. The slope shall be measured as shown in Fig. 11. Transitions from ramps to walks, gutters, or streets shall be flush and free of abrupt changes. Maximum slopes of adjoining gutters, road surface immediately adjacent to the curb ramp, or accessible route shall not exceed 1:20.

**4.7.3 Width.** The minimum width of a curb ramp shall be 36 in (915 mm), exclusive of flared sides.

**4.7.4 Surface.** Surfaces of curb ramps shall comply with 4.5.

**4.7.5 Sides of Curb Ramps.** If a curb ramp is located where pedestrians must walk across the ramp, or where it is not protected by handrails or guardrails, it shall have flared sides; the maximum slope of the flare shall be 1:10 (see Fig. 12(a)). Curb ramps with returned curbs may be used where pedestrians would not normally walk across the ramp (see Fig. 12(b)).

**4.7.6 Built-up Curb Ramps.** Built-up curb ramps shall be located so that they do not project into vehicular traffic lanes (see Fig. 13).

**4.7.7 Detectable Warnings.** A curb ramp shall have a detectable warning complying with 4.29.2. The detectable warning shall extend the full width and depth of the curb ramp.

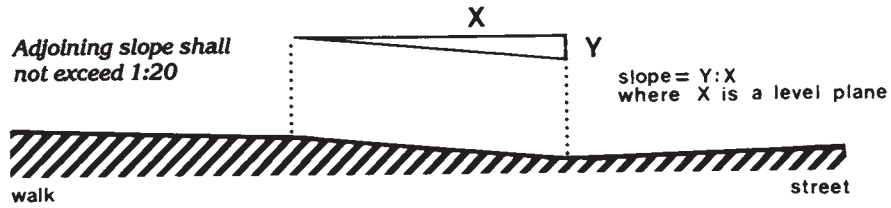
**4.7.8 Obstructions.** Curb ramps shall be located or protected to prevent their obstruction by parked vehicles.

**4.7.9 Location at Marked Crossings.** Curb ramps at marked crossings shall be wholly contained within the markings, excluding any flared sides (see Fig. 15).

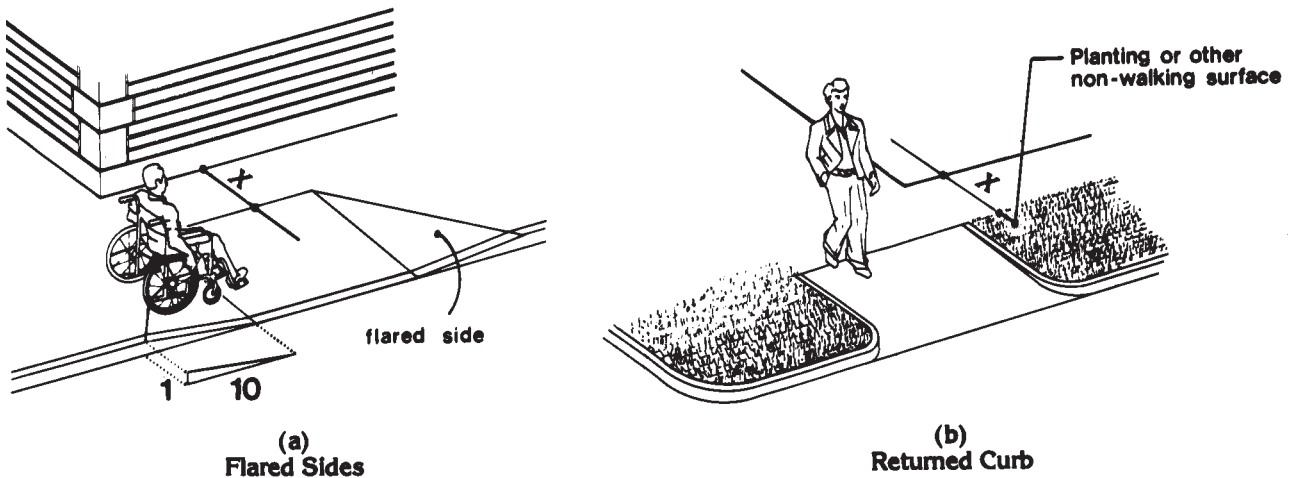
**4.7.10 Diagonal Curb Ramps.** If diagonal (or corner type) curb ramps have returned curbs or other well-defined edges, such edges shall be parallel to the direction of pedestrian flow. The bottom of diagonal curb ramps shall have 48 in (1220 mm) minimum clear space as shown in Fig. 15(c) and (d). If diagonal curb ramps are provided at marked crossings, the 48 in (1220 mm) clear space shall be within the markings (see Fig. 15(c) and (d)). If diagonal curb ramps have flared sides, they shall also have at least a 24 in (610 mm) long segment of straight curb located on each side of the curb ramp and within the marked crossing (see Fig. 15(c)).

**4.7.11 Islands.** Any raised islands in crossings shall be cut through level with the street or have curb ramps at both sides and a level area at least 48 in (1220 mm) long between the curb ramps in the part of the island intersected by the crossings (see Fig. 15(a) and (b)).

**4.8 Ramps.**

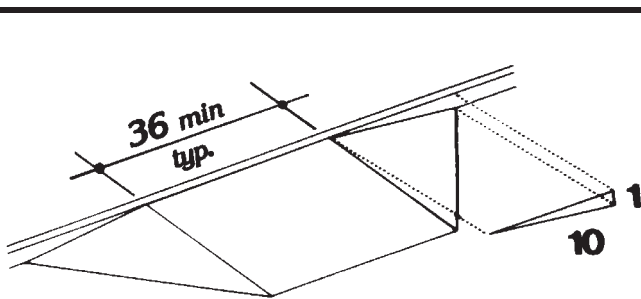


**Fig. 11**  
**Measurement of Curb Ramp Slopes**



If X is less than 48 in., then the slope of the flared side shall not exceed 1:12.

**Fig. 12**  
**Sides of Curb Ramps**



**Fig. 13**  
**Built-Up Curb Ramp**

**4.8 Ramps.**

**4.8.1\* General.** Any part of an accessible route with a slope greater than 1:20 shall be considered a ramp and shall comply with 4.8.

**4.8.2\* Slope and Rise.** The least possible slope shall be used for any ramp. The maximum slope of a ramp in new construction shall be 1:12. The maximum rise for any run shall be 30 in (760 mm) (see Fig. 16). Curb ramps and ramps to be constructed on existing sites or in existing buildings or facilities may have slopes and rises as allowed in 4.1.6(3)(a) if space limitations prohibit the use of a 1:12 slope or less.

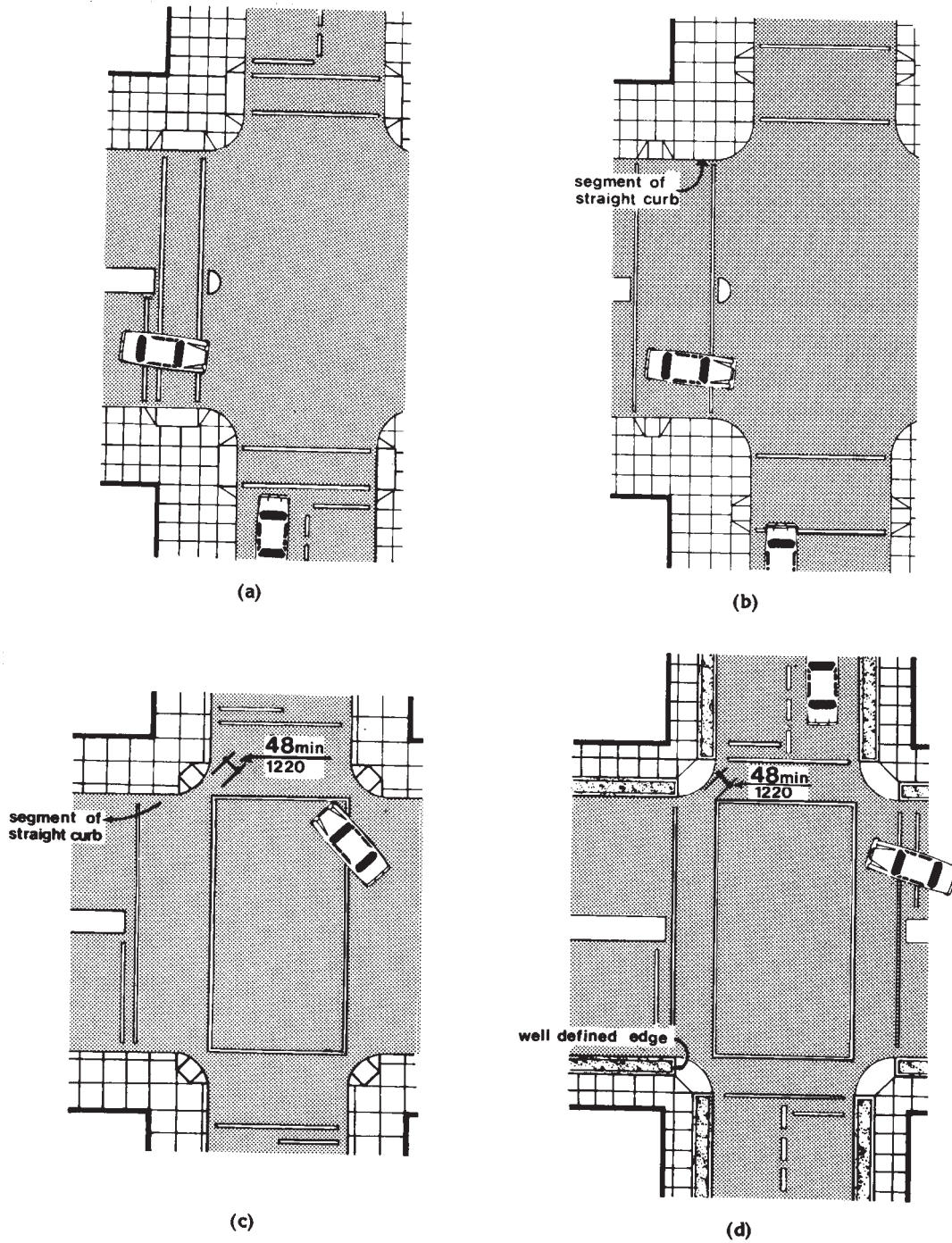
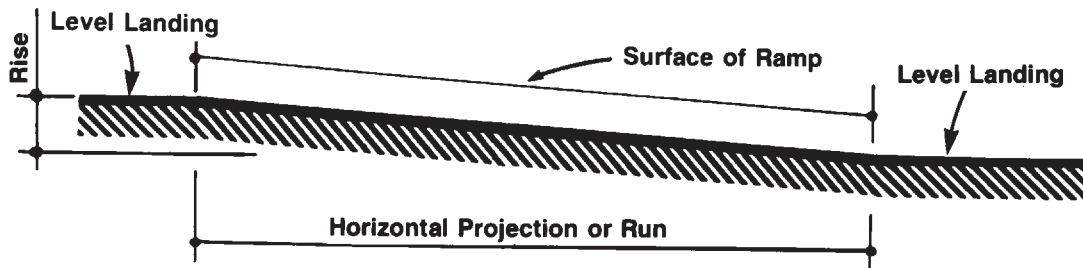


Fig. 15  
Curb Ramps at Marked Crossings

## 4.8 Ramps.



Slope	Maximum Rise		Maximum Horizontal Projection	
	in	mm	ft	m
1:12 to < 1:16	30	760	30	9
1:16 to < 1:20	30	760	40	12

**Fig. 16**

**Components of a Single Ramp Run and Sample Ramp Dimensions**

**4.8.3 Clear Width.** The minimum clear width of a ramp shall be 36 in (915 mm).

**4.8.4\* Landings.** Ramps shall have level landings at bottom and top of each ramp and each ramp run. Landings shall have the following features:

- (1) The landing shall be at least as wide as the ramp run leading to it.
- (2) The landing length shall be a minimum of 60 in (1525 mm) clear.
- (3) If ramps change direction at landings, the minimum landing size shall be 60 in by 60 in (1525 mm by 1525 mm).
- (4) If a doorway is located at a landing, then the area in front of the doorway shall comply with 4.13.6.

**4.8.5\* Handrails.** If a ramp run has a rise greater than 6 in (150 mm) or a horizontal projection greater than 72 in (1830 mm), then it shall have handrails on both sides. Handrails are not required on curb ramps or adjacent to seating

in assembly areas. Handrails shall comply with 4.26 and shall have the following features:

- (1) Handrails shall be provided along both sides of ramp segments. The inside handrail on switchback or dogleg ramps shall always be continuous.
- (2) If handrails are not continuous, they shall extend at least 12 in (305 mm) beyond the top and bottom of the ramp segment and shall be parallel with the floor or ground surface (see Fig. 17).
- (3) The clear space between the handrail and the wall shall be 1 - 1/2 in (38 mm).
- (4) Gripping surfaces shall be continuous.
- (5) Top of handrail gripping surfaces shall be mounted between 34 in and 38 in (865 mm and 965 mm) above ramp surfaces.
- (6) Ends of handrails shall be either rounded or returned smoothly to floor, wall, or post.
- (7) Handrails shall not rotate within their fittings.

**4.8.6 Cross Slope and Surfaces.** The cross slope of ramp surfaces shall be no greater than 1:50. Ramp surfaces shall comply with 4.5.

**4.8.7 Edge Protection.** Ramps and landings with drop-offs shall have curbs, walls, railings, or projecting surfaces that prevent people from slipping off the ramp. Curbs shall be a minimum of 2 in (50 mm) high (see Fig. 17).

**4.8.8 Outdoor Conditions.** Outdoor ramps and their approaches shall be designed so that water will not accumulate on walking surfaces.

#### 4.9 Stairs.

**4.9.1\* Minimum Number.** Stairs required to be accessible by 4.1 shall comply with 4.9.

**4.9.2 Treads and Risers.** On any given flight of stairs, all steps shall have uniform riser heights and uniform tread widths. Stair treads shall be no less than 11 in (280 mm) wide, measured from riser to riser (see Fig. 18(a)). Open risers are not permitted.

**4.9.3 Nosings.** The undersides of nosings shall not be abrupt. The radius of curvature at the leading edge of the tread shall be no greater than 1/2 in (13 mm). Risers shall be sloped or the underside of the nosing shall have an angle not less than 60 degrees from the horizontal. Nosings shall project no more than 1-1/2 in (38 mm) (see Fig. 18).

**4.9.4 Handrails.** Stairways shall have handrails at both sides of all stairs. Handrails shall comply with 4.26 and shall have the following features:

(1) Handrails shall be continuous along both sides of stairs. The inside handrail on switchback or dogleg stairs shall always be continuous (see Fig. 19(a) and (b)).

(2) If handrails are not continuous, they shall extend at least 12 in (305 mm) beyond the top riser and at least 12 in (305 mm) plus the width of one tread beyond the bottom riser. At the top, the extension shall be parallel with the floor or ground surface. At the bottom, the handrail shall

continue to slope for a distance of the width of one tread from the bottom riser; the remainder of the extension shall be horizontal (see Fig. 19(c) and (d)). Handrail extensions shall comply with 4.4.

(3) The clear space between handrails and wall shall be 1-1/2 in (38 mm).

(4) Gripping surfaces shall be uninterrupted by newel posts, other construction elements, or obstructions.

(5) Top of handrail gripping surface shall be mounted between 34 in and 38 in (865 mm and 965 mm) above stair nosings.

(6) Ends of handrails shall be either rounded or returned smoothly to floor, wall or post.

(7) Handrails shall not rotate within their fittings.

**4.9.5 Detectable Warnings at Stairs.**  
(Reserved).

**4.9.6 Outdoor Conditions.** Outdoor stairs and their approaches shall be designed so that water will not accumulate on walking surfaces.

#### 4.10 Elevators.

**4.10.1 General.** Accessible elevators shall be on an accessible route and shall comply with 4.10 and with the ASME A17.1-1990, Safety Code for Elevators and Escalators. Freight elevators shall not be considered as meeting the requirements of this section unless the only elevators provided are used as combination passenger and freight elevators for the public and employees.

**4.10.2 Automatic Operation.** Elevator operation shall be automatic. Each car shall be equipped with a self-leveling feature that will automatically bring the car to floor landings within a tolerance of 1/2 in (13 mm) under rated loading to zero loading conditions. This self-leveling feature shall be automatic and independent of the operating device and shall correct the over-travel or under-travel.

**4.27.4 Operation.** Controls and operating mechanisms shall be operable with one hand and shall not require tight grasping, pinching, or twisting of the wrist. The force required to activate controls shall be no greater than 5 lbf (22.2 N).

#### 4.28 Alarms.

**4.28.1 General.** Alarm systems required to be accessible by 4.1 shall comply with 4.28. At a minimum, visual signal appliances shall be provided in buildings and facilities in each of the following areas: restrooms and any other general usage areas (e.g., meeting rooms), hallways, lobbies, and any other area for common use.

**4.28.2\* Audible Alarms.** If provided, audible emergency alarms shall produce a sound that exceeds the prevailing equivalent sound level in the room or space by at least 15 dbA or exceeds any maximum sound level with a duration of 60 seconds by 5 dbA, whichever is louder. Sound levels for alarm signals shall not exceed 120 dbA.

**4.28.3\* Visual Alarms.** Visual alarm signal appliances shall be integrated into the building or facility alarm system. If single station audible alarms are provided then single station visual alarm signals shall be provided. Visual alarm signals shall have the following minimum photometric and location features:

(1) The lamp shall be a xenon strobe type or equivalent.

(2) The color shall be clear or nominal white (i.e., unfiltered or clear filtered white light).

(3) The maximum pulse duration shall be two-tenths of one second (0.2 sec) with a maximum duty cycle of 40 percent. The pulse duration is defined as the time interval between initial and final points of 10 percent of maximum signal.

(4) The intensity shall be a minimum of 75 candela.

(5) The flash rate shall be a minimum of 1 Hz and a maximum of 3 Hz.

(6) The appliance shall be placed 80 in (2030 mm) above the highest floor level within the space or 6 in (152 mm) below the ceiling, whichever is lower.

(7) In general, no place in any room or space required to have a visual signal appliance shall be more than 50 ft (15 m) from the signal (in the horizontal plane). In large rooms and spaces exceeding 100 ft (30 m) across, without obstructions 6 ft (2 m) above the finish floor, such as auditoriums, devices may be placed around the perimeter, spaced a maximum 100 ft (30 m) apart, in lieu of suspending appliances from the ceiling.

(8) No place in common corridors or hallways in which visual alarm signalling appliances are required shall be more than 50 ft (15 m) from the signal.

**4.28.4\* Auxiliary Alarms.** Units and sleeping accommodations shall have a visual alarm connected to the building emergency alarm system or shall have a standard 110-volt electrical receptacle into which such an alarm can be connected and a means by which a signal from the building emergency alarm system can trigger such an auxiliary alarm. When visual alarms are in place the signal shall be visible in all areas of the unit or room. Instructions for use of the auxiliary alarm or receptacle shall be provided.

#### 4.29 Detectable Warnings.

**4.29.1 General.** Detectable warnings required by 4.1 and 4.7 shall comply with 4.29.

**4.29.2\* Detectable Warnings on Walking Surfaces.** Detectable warnings shall consist of raised truncated domes with a diameter of nominal 0.9 in (23 mm), a height of nominal 0.2 in (5 mm) and a center-to-center spacing of nominal 2.35 in (60 mm) and shall contrast visually with adjoining surfaces, either light-on-dark, or dark-on-light.

The material used to provide contrast shall be an integral part of the walking surface. Detectable warnings used on interior surfaces shall differ

**4.30 Signage.**

from adjoining walking surfaces in resiliency or sound-on-cane contact.

**4.29.3 Detectable Warnings on Doors To Hazardous Areas.** (Reserved).

**4.29.4 Detectable Warnings at Stairs.** (Reserved).

**4.29.5 Detectable Warnings at Hazardous Vehicular Areas.** If a walk crosses or adjoins a vehicular way, and the walking surfaces are not separated by curbs, railings, or other elements between the pedestrian areas and vehicular areas, the boundary between the areas shall be defined by a continuous detectable warning which is 36 in (915 mm) wide, complying with 4.29.2.

**4.29.6 Detectable Warnings at Reflecting Pools.** The edges of reflecting pools shall be protected by railings, walls, curbs, or detectable warnings complying with 4.29.2.

**4.29.7 Standardization.** (Reserved).

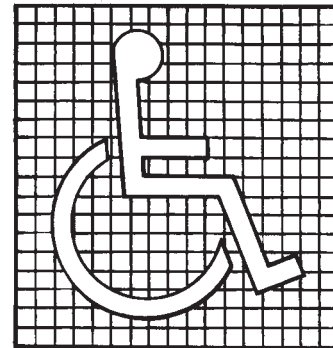
**4.30 Signage.**

**4.30.1\* General.** Signage required to be accessible by 4.1 shall comply with the applicable provisions of 4.30.

**4.30.2\* Character Proportion.** Letters and numbers on signs shall have a width-to-height ratio between 3:5 and 1:1 and a stroke-width-to-height ratio between 1:5 and 1:10.

**4.30.3 Character Height.** Characters and numbers on signs shall be sized according to the viewing distance from which they are to be read. The minimum height is measured using an upper case X. Lower case characters are permitted.

Height Above Finished Floor	Minimum Character Height
Suspended or Projected Overhead in compliance with 4.4.2	3 in (75 mm) minimum



(a)  
Proportions  
International Symbol of Accessibility



(b)  
Display Conditions  
International Symbol of Accessibility



(c)  
International TDD Symbol



(d)  
International Symbol of Access for Hearing Loss

**Fig. 43**  
**International Symbols**

## 10.0 Transportation Facilities.

clear door width of 32 in (815 mm), minimum turning space complying with 4.2.3, one water closet complying with 4.16, one lavatory complying with 4.19 and the door shall have a privacy latch; and, if provided, at least one tub or shower shall comply with 4.20 or 4.21, respectively.

(d) at least one common area which a person with mobility impairments can approach, enter and exit including a minimum clear door width of 32 in (815 mm).

(e) at least one route connecting elements (a), (b), (c) and (d) which a person with mobility impairments can use including minimum clear width of 36 in (915 mm), passing space complying with 4.3.4, turning space complying with 4.2.3 and changes in levels complying with 4.3.8.

(f) homeless shelters can comply with the provisions of (a)-(e) by providing the above elements on one accessible floor.

**9.5.3. Accessible Sleeping Accommodations in New Construction.** Accessible sleeping rooms shall be provided in conformance with the table in 9.1.2 and shall comply with 9.2 Accessible Units, Sleeping Rooms and Suites (where the items are provided). Additional sleeping rooms that comply with 9.3 Sleeping Accommodations for Persons with Hearing Impairments shall be provided in conformance with the table provided in 9.1.3.

In facilities with multi-bed rooms or spaces, a percentage of the beds equal to the table provided in 9.1.2 shall comply with 9.2.2(1).

<b>10.</b>	<b>TRANSPORTATION FACILITIES.</b>
------------	-----------------------------------

**10.1 General.** Every station, bus stop, bus stop pad, terminal, building or other transportation facility, shall comply with the applicable provisions of section 4, the special application sections, and the applicable provisions of this section.

## 10.2 Bus Stops and Terminals.

### 10.2.1 New Construction.

(1) Where new bus stop pads are constructed at bus stops, bays or other areas where a lift or ramp is to be deployed, they shall have a firm, stable surface; a minimum clear length of 96 inches (measured from the curb or vehicle roadway edge) and a minimum clear width of 60 inches (measured parallel to the vehicle roadway) to the maximum extent allowed by legal or site constraints; and shall be connected to streets, sidewalks or pedestrian paths by an accessible route complying with 4.3 and 4.4. The slope of the pad parallel to the roadway shall, to the extent practicable, be the same as the roadway. For water drainage, a maximum slope of 1:50 (2%) perpendicular to the roadway is allowed.

(2) Where provided, new or replaced bus shelters shall be installed or positioned so as to permit a wheelchair or mobility aid user to enter from the public way and to reach a location, having a minimum clear floor area of 30 inches by 48 inches, entirely within the perimeter of the shelter. Such shelters shall be connected by an accessible route to the boarding area provided under paragraph (1) of this section.

(3) Where provided, all new bus route identification signs shall comply with 4.30.5. In addition, to the maximum extent practicable, all new bus route identification signs shall comply with 4.30.2 and 4.30.3. Signs that are sized to the maximum dimensions permitted under legitimate local, state or federal regulations or ordinances shall be considered in compliance with 4.30.2 and 4.30.3 for purposes of this section.

EXCEPTION: Bus schedules, timetables, or maps that are posted at the bus stop or bus bay are not required to comply with this provision.

### 10.2.2 Bus Stop Siting and Alterations.

(1) Bus stop sites shall be chosen such that, to the maximum extent practicable, the areas where lifts or ramps are to be deployed comply with section 10.2.1(1) and (2).

(2) When new bus route identification signs are installed or old signs are replaced, they shall comply with the requirements of 10.2.1(3).

**10.3 Fixed Facilities and Stations.**

**10.3.1 New Construction.** New stations in rapid rail, light rail, commuter rail, intercity bus, intercity rail, high speed rail, and other fixed guideway systems (e.g., automated guideway transit, monorails, etc.) shall comply with the following provisions, as applicable:

(1) Elements such as ramps, elevators or other circulation devices, fare vending or other ticketing areas, and fare collection areas shall be placed to minimize the distance which wheelchair users and other persons who cannot negotiate steps may have to travel compared to the general public. The circulation path, including an accessible entrance and an accessible route, for persons with disabilities shall, to the maximum extent practicable, coincide with the circulation path for the general public. Where the circulation path is different, signage complying with 4.30.1, 4.30.2, 4.30.3, 4.30.5, and 4.30.7(1) shall be provided to indicate direction to and identify the accessible entrance and accessible route.

(2) In lieu of compliance with 4.1.3(8), at least one entrance to each station shall comply with 4.14, Entrances. If different entrances to a station serve different transportation fixed routes or groups of fixed routes, at least one entrance serving each group or route shall comply with 4.14, Entrances. All accessible entrances shall, to the maximum extent practicable, coincide with those used by the majority of the general public.

(3) Direct connections to commercial, retail, or residential facilities shall have an accessible route complying with 4.3 from the point of connection to boarding platforms and all transportation system elements used by the public. Any elements provided to facilitate future direct connections shall be on an accessible route connecting boarding platforms and all transportation system elements used by the public.

(4) Where signs are provided at entrances to stations identifying the station or the entrance, or both, at least one sign at each entrance shall comply with 4.30.4 and 4.30.6. Such signs shall be placed in uniform locations at entrances within the transit system to the maximum extent practicable.

EXCEPTION: Where the station has no defined entrance, but signage is provided, then the accessible signage shall be placed in a central location.

(5) Stations covered by this section shall have identification signs complying with 4.30.1, 4.30.2, 4.30.3, and 4.30.5. Signs shall be placed at frequent intervals and shall be clearly visible from within the vehicle on both sides when not obstructed by another train. When station identification signs are placed close to vehicle windows (i.e., on the side opposite from boarding) each shall have the top of the highest letter or symbol below the top of the vehicle window and the bottom of the lowest letter or symbol above the horizontal mid-line of the vehicle window.

(6) Lists of stations, routes, or destinations served by the station and located on boarding areas, platforms, or mezzanines shall comply with 4.30.1, 4.30.2, 4.30.3, and 4.30.5. A minimum of one sign identifying the specific station and complying with 4.30.4 and 4.30.6 shall be provided on each platform or boarding area. All signs referenced in this paragraph shall, to the maximum extent practicable, be placed in uniform locations within the transit system.

(7)\* Automatic fare vending, collection and adjustment (e.g., add-fare) systems shall comply with 4.34.2, 4.34.3, 4.34.4, and 4.34.5. At each accessible entrance such devices shall be located on an accessible route. If self-service fare collection devices are provided for the use of the general public, at least one accessible device for entering, and at least one for exiting, unless one device serves both functions, shall be provided at each accessible point of entry or exit. Accessible fare collection devices shall have a minimum clear opening width of 32 in; shall permit passage of a

### 10.3 Fixed Facilities and Stations.

wheelchair; and, where provided, coin or card slots and controls necessary for operation shall comply with 4.27. Gates which must be pushed open by wheelchair or mobility aid users shall have a smooth continuous surface extending from 2 inches above the floor to 27 inches above the floor and shall comply with 4.13. Where the circulation path does not coincide with that used by the general public, accessible fare collection systems shall be located at or adjacent to the accessible point of entry or exit.

(8) Platform edges bordering a drop-off and not protected by platform screens or guard rails shall have a detectable warning. Such detectable warnings shall comply with 4.29.2 and shall be 24 inches wide running the full length of the platform drop-off.

(9) In stations covered by this section, rail-to-platform height in new stations shall be coordinated with the floor height of new vehicles so that the vertical difference, measured when the vehicle is at rest, is within plus or minus 5/8 inch under normal passenger load conditions. For rapid rail, light rail, commuter rail, high speed rail, and intercity rail systems in new stations, the horizontal gap, measured when the new vehicle is at rest, shall be no greater than 3 inches. For slow moving automated guideway "people mover" transit systems, the horizontal gap in new stations shall be no greater than 1 inch.

EXCEPTION 1: Existing vehicles operating in new stations may have a vertical difference with respect to the new platform within plus or minus 1-1/2 inches.

EXCEPTION 2: In light rail, commuter rail and intercity rail systems where it is not operationally or structurally feasible to meet the horizontal gap or vertical difference requirements, mini-high platforms, car-borne or platform-mounted lifts, ramps or bridge plates, or similar manually deployed devices, meeting the applicable requirements of 36 C.F.R. part 1192, or 49 CFR part 38 shall suffice.

(10) Stations shall not be designed or constructed so as to require persons with

disabilities to board or alight from a vehicle at a location other than one used by the general public.

(11) Illumination levels in the areas where signage is located shall be uniform and shall minimize glare on signs. Lighting along circulation routes shall be of a type and configuration to provide uniform illumination.

(12) Text Telephones: The following shall be provided in accordance with 4.31.9:

(a) If an interior public pay telephone is provided in a transit facility (as defined by the Department of Transportation) at least one interior public text telephone shall be provided in the station.

(b) Where four or more public pay telephones serve a particular entrance to a rail station and at least one is in an interior location, at least one interior public text telephone shall be provided to serve that entrance. Compliance with this section constitutes compliance with section 4.1.3(17)(c).

(13) Where it is necessary to cross tracks to reach boarding platforms, the route surface shall be level and flush with the rail top at the outer edge and between rails, except for a maximum 2-1/2 inch gap on the inner edge of each rail to permit passage of wheel flanges. Such crossings shall comply with 4.29.5. Where gap reduction is not practicable, an above-grade or below-grade accessible route shall be provided.

(14) Where public address systems are provided to convey information to the public in terminals, stations, or other fixed facilities, a means of conveying the same or equivalent information to persons with hearing loss or who are deaf shall be provided.

(15) Where clocks are provided for use by the general public, the clock face shall be uncluttered so that its elements are clearly visible. Hands, numerals, and/or digits shall contrast with the background either light-on-dark or dark-on-light. Where clocks are mounted overhead, numerals



**Building a True Community**  
Final Report  
Public Rights-of-Way Access Advisory Committee

January 10, 2001

---

U.S. Architectural & Transportation Barriers Compliance Board

Recommendations of the  
**Public Rights-of-Way Access Advisory Committee**  
to the  
**U.S. Access Board**  
**Final Report: Building a True Community**

prepared by the Editorial Subcommittee

Janet Barlow  
Pat Cannon  
Dan Dawson  
Hol'Lynn D'Lil  
Laurie Kozisek  
Gina Hilberry (Illustrations Manager)  
Elizabeth Hilton  
Jerry Markesino (PROWAAC Chair)  
Charlie Nagel  
Mary O'Connor  
Debbie Ryan  
Ellen Vanderslice (Editorial Subcommittee Chair)  
Francine Wai  
Mark Wales

With the assistance of Access Board staff members:

Dennis Cannon  
Beth Stewart  
Lois Thibault  
Scott Windley

- Crosswalk markings are required at signalized intersections.
- The minimum crosswalk width is 8 feet.

#### **Crossing times (X02.5.5)**

- Pedestrian signal phase timing shall be calculated with a 3.5 feet per second pedestrian walk speed.
- Crossing distances, when calculating timing, shall include the length of the crosswalk and one curb ramp.

#### **Medians and pedestrian refuge islands (X02.5.6)**

- Compliant cut-throughs or curb ramps are required.
- Detectable warnings are required.

#### **Detectable warnings (X02.5.7)**

- Detectable warnings shall be provided only: 1) where a pedestrian way crosses a vehicular way, but not at unsignalized driveways; 2) where a rail system crosses a pedestrian way; 3) at reflecting pools in the public right-of-way; 4) at cuts through islands and medians; and 5) where required by proposed ADAAG Chapter 10.
- Specifications are provided for size, location, dome spacing and size, alignment, and visual contrast.

#### **Pedestrian overpasses and underpasses (X02.5.8)**

- Overpasses and underpasses must connect to a pedestrian access route.
- An elevator is required if more than 5 percent grade is required for greater than a 5-foot vertical rise.
- Signs must be tactile and visual and comply with proposed ADAAG §504.

#### **Roundabouts (X02.5.9)**

- Barriers must be provided where pedestrian crossings are prohibited.
- A cue must be provided to locate the pedestrian crossing.
- A pedestrian activated traffic signal must be provided at pedestrian crossings.

#### **Turn lanes at intersections (X02.5.10)**

- A cue must be provided to locate the pedestrian crossing.
- A pedestrian activated traffic signal must be provided at pedestrian crossings.

#### **Vehicular Ways and Facilities (X02.6)**

##### **On-street parking (X02.6.1)**

- The number of accessible spaces shall comply with proposed ADAAG §F208.2.
- One in eight, but at least one, accessible space must be van accessible.

*contacts a gutter lip, the caster wheels may be deflected and quickly stop the chair. Depending upon the velocity at the time of contact, the user may be thrown forward from the wheelchair. The degree of stormwater channelization provided by a drainage lip is not sufficient to offset the hazard it creates for pedestrians with disabilities.*

**Research need:** *Research is needed to develop design alternatives to minimize the adverse effect on wheelchair travel of surfaces that contain grade breaks.*

**X02.4.12 Detectable warnings.** Sidewalk/street transitions shall have a detectable warning complying with §X02.5.7.

**EXCEPTION:** Detectable warnings shall not be provided where the sidewalk/street transition occurs at an unsignalized driveway.

**Discussion:** *The committee recognized that some currently manufactured detectable warning products cannot be installed on warped surfaces or surfaces with grade breaks. The industry will need to accept the challenge to develop detectable warning surface materials that will be usable in non-planar applications.*

**X02.4.13 Vehicular obstructions.** Curb ramps and flush landings shall be located or protected so that legally parked vehicles do not obstruct the pedestrian access route.

**Discussion:** *It was agreed that there is a need for a provision related to preventing the obstruction of the pedestrian access route by legally parked cars. The recommended provision is consistent with Interim Final Rule section 14.2.4. Public agencies should consider lengthening the no parking zone adjacent to a crosswalk, since wheelchair users and people of short stature may be hidden from a motorist's view by parked cars.*

**X02.4.14 Curb type.** Reserved.

**Frontier issue:** *The committee discussed and wishes to add the following proposal to the list of frontier issues: To aid in the protection of all pedestrians at intersection corners, and to make intersection geometry more cane detectable, the committee suggests that where rolled or "rollover" curb sections are proposed in new construction, a transition be provided from the rolled curb section to a barrier or vertical curb section of at least the same height and running the entire return of the curb return, and within 10 feet of the edge of each curb ramp (excluding flares) or the flush street transition.*

## **X02.5 Pedestrian Street Crossings.**

### **X02.5.1 Pedestrian signal push buttons.**

**X02.5.1.1 General.** Where new traffic signals with pedestrian controls are installed, they shall comply with this section.

**X02.5.1.2 Features.** Push buttons shall have the following features.

**(A) Size.** Push buttons shall be a minimum of 2 inches (51 mm) across in at least one dimension.

**(B) Maximum force.** The force required to activate push buttons shall be no greater than 3.5 pounds (15.5N).

**(C) Operation.** Push buttons shall be operable with a closed fist.

**(D) Locator tone.** There shall be a locator tone complying with X02.5.1.5.

**(E) Visual contrast.** Push buttons shall have a visual contrast with the body background of at least 70 percent.

**(F) Indicator.** There shall be a visible and audible indicator that the button press has occurred.

**Advisory:** *A long button press (e.g., 3 seconds) may bring up the accessible features or additional accessibility features of the individual device. An additional button should not be used to bring up additional accessibility features. All accessible features available are to be actuated in the same way. Thus, for a given signal, a long button press could request more than one additional feature. Possible additional features include:*

- 1. sound beaconing by increasing the volume of the WALK tone and the associated locator tone for one signal cycle, so a blind pedestrian might be able to use the sound from the opposite side of the street to provide alignment information;*
- 2. sound beaconing by alternating the audible WALK signal back and forth from one end of the crosswalk to the other;*
- 3. providing extended crossing time; and*
- 4. providing a voice message with the street names at the intersection.*

**(F) Signage.** Signage accompanying push buttons shall comply with §X02.5.1.4.

**Discussion:** *These specifications are intended to make pedestrian push buttons accessible. The recommended change to a reduced maximum operating force is based*

*in part, on the preamble to proposed ADAAG 309 Operable Parts (p 62262, 2<sup>nd</sup> col): "Information indicates that most control buttons of keys can meet a 3.5 maximum pounds of force and a maximum stroke depth of 1/10 inches." The closed fist requirement is based on the Access Board's design guidelines: "Devices that can be operated by a closed fist acting on any point on the surface will be most usable by pedestrians who have mobility impairments." The provision of visual contrast and a locator tone enable blind or visually impaired pedestrians to locate the push button. The visible and audible indicator informs both visually impaired and sighted individuals that the request for a walk signal has been received.*

**X02.5.1.3 Push button location.** The location of push buttons shall be in accordance with the following minimum requirements.

**(A) Adjacent to landing.** The push button shall be mounted adjacent to a clear ground space or a landing on the pedestrian access route leading to the crosswalk. The clear ground space shall be at least 32 inches by 54 inches (815 by 1370 mm), shall slope no more than 1:48 in any direction, and shall be provided with a stable, firm and slip resistant surface from which to operate controls. This clear ground space may overlap entirely with the pedestrian access route.

**(B) Proximity to approach.** Where a parallel approach to the push button is provided, controls shall be within 10 inches (255 mm) of the clear ground space, measured horizontally, and centered on it. Where a forward approach is provided, controls shall abut and be centered on the clear ground space.

**(C) Direction of control face.** The control face of the push button shall be parallel to the direction of the crosswalk controlled by the push button, and no closer than 30 inches (760 mm) to the curb line.

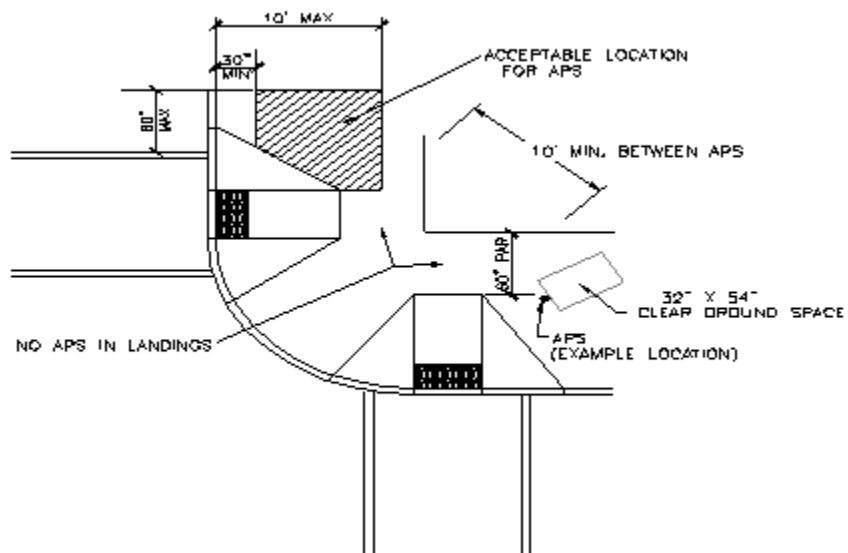
**(D) Mounting height.** The centerline of the push button shall be mounted 42 inches (1070 mm) above the clear ground space for approach.

**(E) Close to crosswalk.** The push button shall be mounted no further than 5 feet (1.5m) from the extension of the crosswalk lines, and within 10 feet (3m) of the curb line, unless the curb ramp is longer than 10 feet (3m).

**(F) Proximity to curb or transition ramp.** When located at a curb ramp, the push button shall be placed within 24 inches (610 mm) horizontally of the top corner of the curb ramp, on the side furthest from the center of the intersection of the roadway. When located at a transition ramp, the push button shall be placed adjacent to the lower landing.

**Advisory:** It should be noted that for information in vibrotactile format to be useable, the pole must be located so the user is able to keep a hand on the button while aligned at the top of the curb ramp or at the crosswalk. Note: vibrotactile information alone is not allowed.

**(G) Separation.** Where there are two accessible pedestrian signals on the same corner, the push buttons shall be mounted on poles separated by at least 10 feet (3 meters).

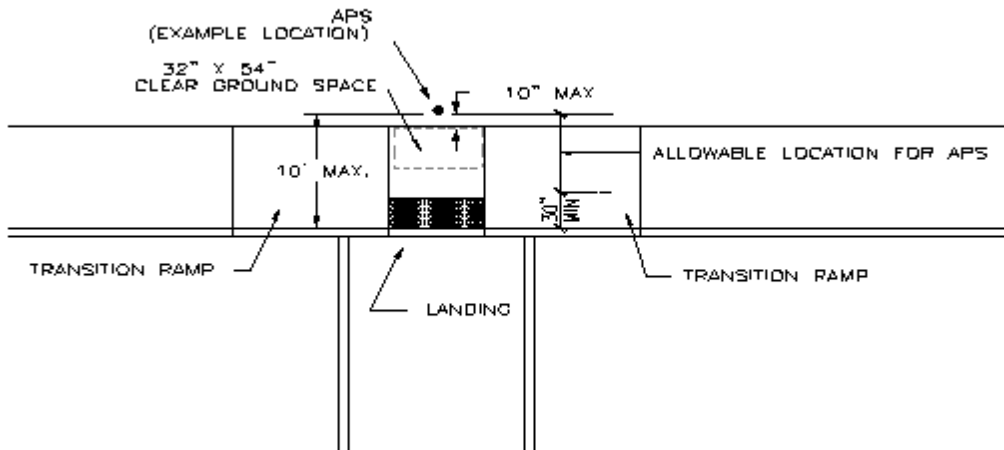


**Figure X02.5 A Curb Ramp APS Zones**

Curb ramps at an intersection with APS zones indicated in plan.

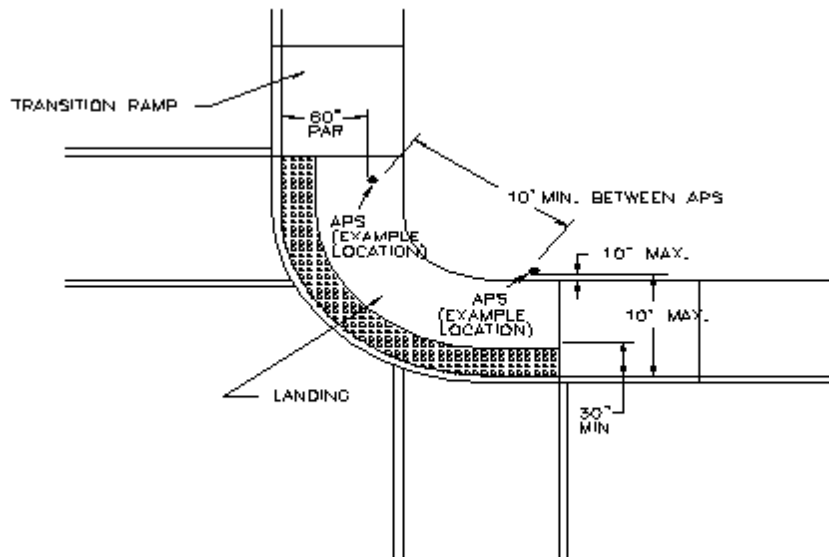
**EXCEPTION:** If the requirement for separation cannot be met due to location requirements (A) through (G), two accessible pedestrian signal-related push buttons may be installed on a single pole. If installed on the same pole, the APS must be equipped to provide speech-transmitted data or other technology that delivers an unambiguous message about which crosswalk has the walk signal indication.

THIS REPORT CONTAINS THE RECOMMENDATIONS OF THE PUBLIC RIGHTS-OF-WAY ACCESS ADVISORY COMMITTEE FOR THE USE OF THE U.S. ACCESS BOARD IN DEVELOPING GUIDELINES FOR NEWLY CONSTRUCTED OR ALTERED PEDESTRIAN FACILITIES COVERED BY TITLE II OF THE AMERICANS WITH DISABILITIES ACT (ADA) OR THE ARCHITECTURAL BARRIERS ACT (ABA). THIS IS NOT A REGULATION.



**Figure X02.5 B Transition Ramp APS Zones**

Transition ramps at an intersection with APS zones indicated in plan.



**Figure X02.5 C Shared Curb Ramp APS Zones**

Shared ramp at an intersection with APS zones indicated in plan.

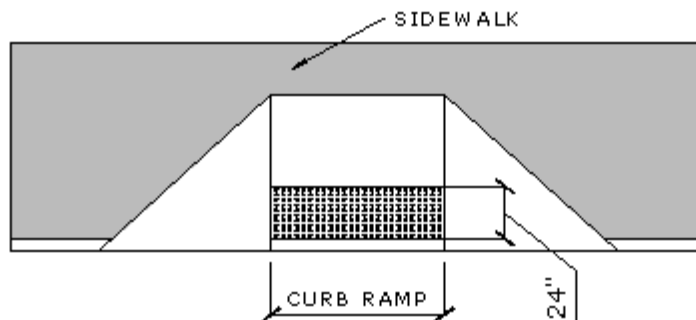
**X02.5.6.2 Detectable Warnings.** Curb ramps at medians and refuge islands, and locations where medians and refuge islands are cut through level with the street at crosswalks, shall have detectable warnings complying with §X02.5.7.

**X02.5.7 Detectable warnings.**

**X02.5.7.1 General.** Where required, detectable warnings shall comply with §X02.5.7.

**X02.5.7.2 Application.** Detectable warnings shall be provided only at the following locations:

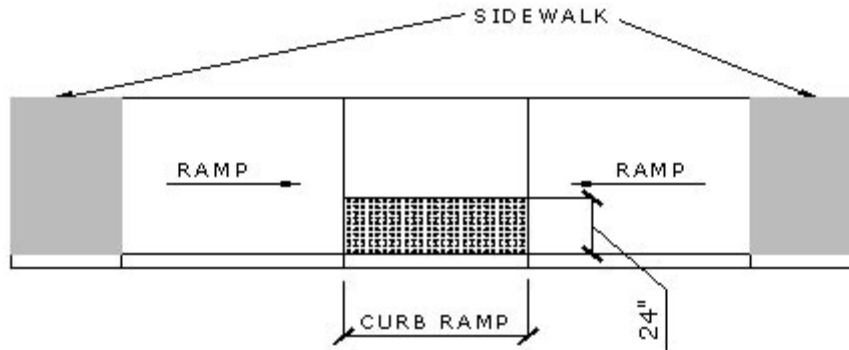
**(A)** Where a sidewalk crosses a vehicular way, excluding unsignalized driveway crossings.



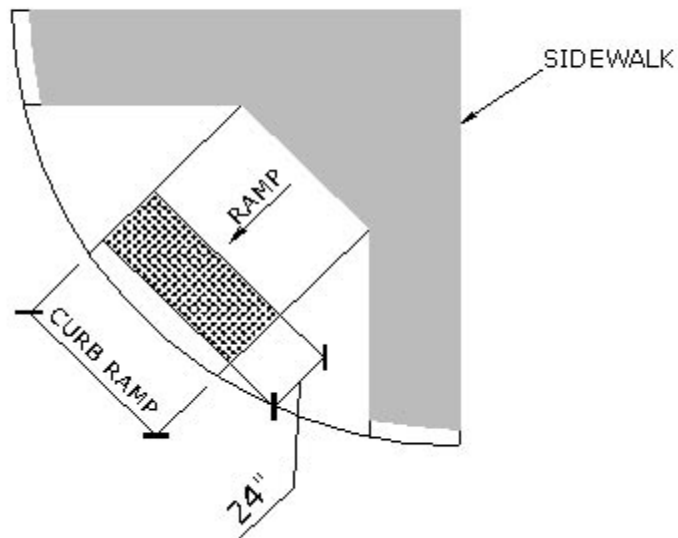
**Figure X02.5 G Detectable Warning at Curb Ramp**

Illustrates 24" deep detectable warning located near the street edge of the curb ramp.

THIS REPORT CONTAINS THE RECOMMENDATIONS OF THE PUBLIC RIGHTS-OF-WAY ACCESS ADVISORY COMMITTEE FOR THE USE OF THE U.S. ACCESS BOARD IN DEVELOPING GUIDELINES FOR NEWLY CONSTRUCTED OR ALTERED PEDESTRIAN FACILITIES COVERED BY TITLE II OF THE AMERICANS WITH DISABILITIES ACT (ADA) OR THE ARCHITECTURAL BARRIERS ACT (ABA). THIS IS NOT A REGULATION.

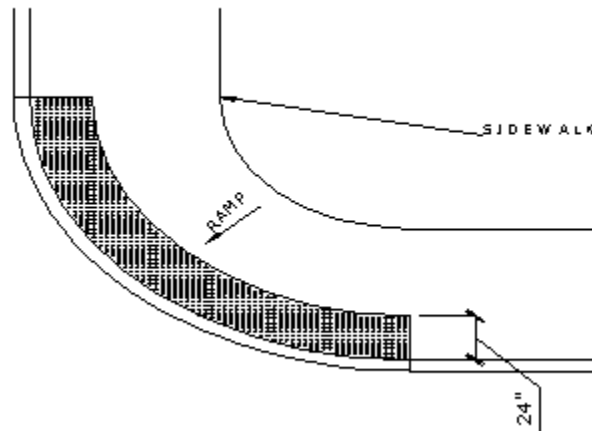


**Figure X02.5 H Transition Ramp with Detectable Warning**  
Shows detectable warning at a transition ramp.

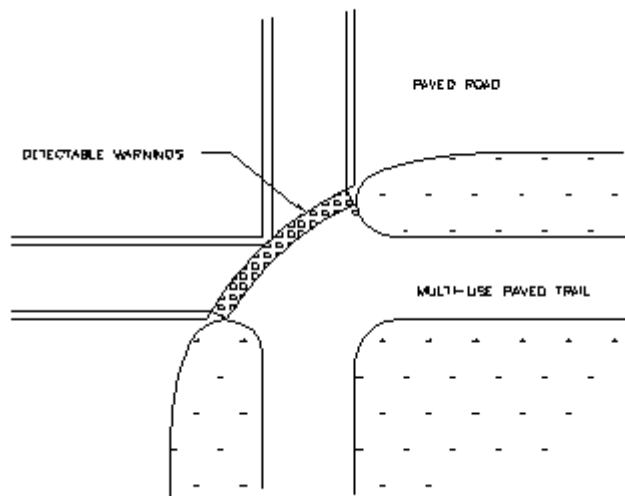


**Figure X02.5 I Shared Curb Ramp with Detectable Warning**  
Shows detectable warning at a shared curb ramp.

THIS REPORT CONTAINS THE RECOMMENDATIONS OF THE PUBLIC RIGHTS-OF-WAY ACCESS ADVISORY COMMITTEE FOR THE USE OF THE U.S. ACCESS BOARD IN DEVELOPING GUIDELINES FOR NEWLY CONSTRUCTED OR ALTERED PEDESTRIAN FACILITIES COVERED BY TITLE II OF THE AMERICANS WITH DISABILITIES ACT (ADA) OR THE ARCHITECTURAL BARRIERS ACT (ABA). THIS IS NOT A REGULATION.



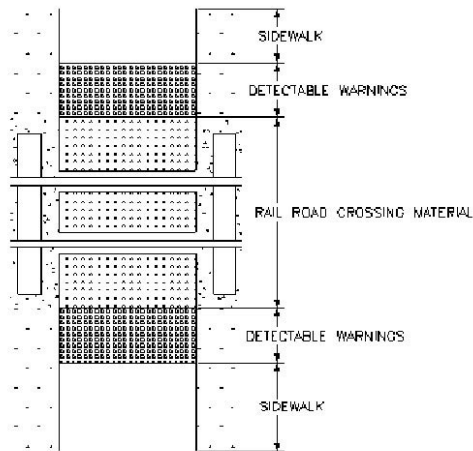
**Figure X02.5 J Detectable Warning at Blended Curb**  
Shows detectable warning at blended curb.



**Figure X02.5 K Detectable Warnings at Multi-Use Path**  
Plan view of a multi-use path and road intersection. Detectable warnings are indicated at the intersection.

THIS REPORT CONTAINS THE RECOMMENDATIONS OF THE PUBLIC RIGHTS-OF-WAY ACCESS ADVISORY COMMITTEE FOR THE USE OF THE U.S. ACCESS BOARD IN DEVELOPING GUIDELINES FOR NEWLY CONSTRUCTED OR ALTERED PEDESTRIAN FACILITIES COVERED BY TITLE II OF THE AMERICANS WITH DISABILITIES ACT (ADA) OR THE ARCHITECTURAL BARRIERS ACT (ABA). THIS IS NOT A REGULATION.

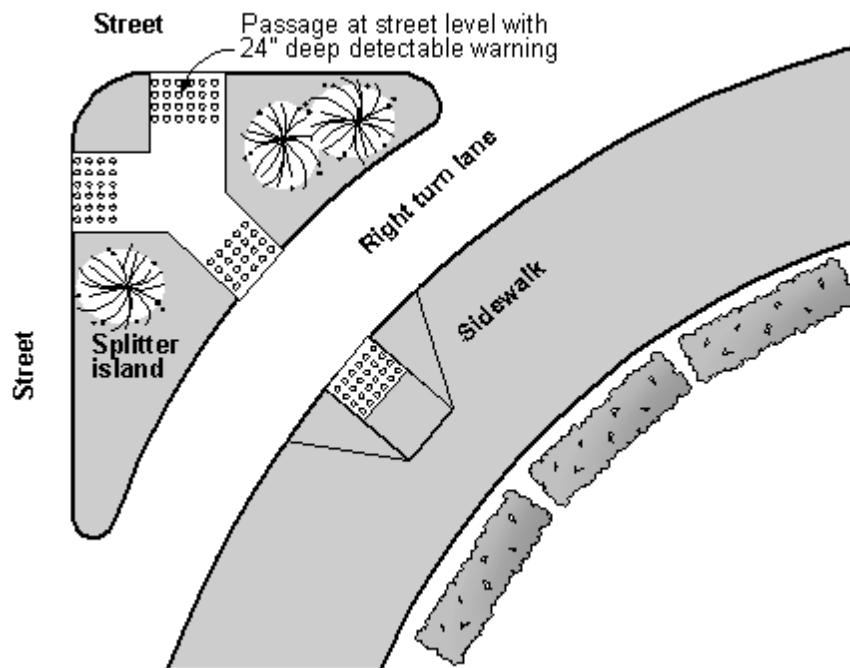
(B) Where a rail system crosses pedestrian facilities that are not shared with vehicular ways.



**Figure X02.5 L Detectable Warnings At Railroad Crossing**  
Plan view of detectable warnings at a railroad crossing.

(C) At reflecting pools within the public right-of-way, which have no curb or rim protruding above the walking surface.

(D) At islands and medians that are cut through level with the roadway.



**Figure X02.5 M Refuge Island with Detectable Warnings**

Plan view of pedestrian passage that cuts through a refuge island at the same level as the street. Detectable warnings are shown at each end of the cuts.

**Advisory:** Where islands or medians are less than 4 feet wide, the detectable warning should extend across the full length of the cut through the island or median.

(E) Where required by proposed ADAAG Chapter 10.

**Discussion:** The detectable warning is a unique and standardized surface intended to function much like a stop sign to alert pedestrians who are blind or visually impaired to the presence of hazards in the line of travel. The truncated dome surface should not be used for wayfinding or directional information. The removal of curbs, which provided a clearly defined indication of the location of the edge of the street, has caused difficulty for individuals who are blind or visually impaired. The locations above were identified by the committee as being appropriate for the installation of detectable warnings.

*Detectable warnings are not required at unsignalized driveways based on comments to the committee that installation at driveways would make it harder to truly identify the streets.*

### **X02.5.7.3 Specifications.**

**(A) Size.** Detectable warnings shall be 24 inches (610 mm) in the direction of travel and extend the full width of the curb ramp or flush surface.

**Discussion:** *Research has confirmed that for persons who are visually impaired, there is a high level of risk of inadvertent street entry associated with the presence of curb ramps, particularly those having slopes of 1:12 or less (Bentzen, B. & Barlow, J., 1995; Hauger, S., Rigby, J., Safewright, M. and McAuley, W., 1996). It has been demonstrated that detectable warnings complying with existing ADAAG §4.29.2 are highly detectable by persons with visual impairments, and can provide an effective stop signal for persons who are blind or visually impaired which can be used to determine the end of the sidewalk and the beginning of the vehicular way. Research has also demonstrated that 24 inches of detectable warning material is sufficient to enable persons who are blind or visually impaired to stop on 90 percent of approaches (Peck, A. & Bentzen, B., 1987).*

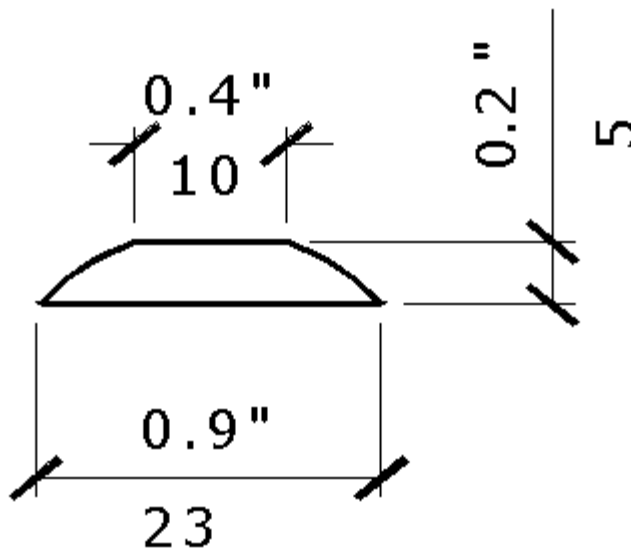
*Research has now been conducted which addresses concerns about safety of detectable warnings for individuals with mobility impairments, indicating that detectable warnings on slopes have minimal impact on the safety and ease of travel for persons having physical disabilities (Bentzen, B., Nolin, T., Easton, R., Desmaris, P., and Mitchell, P., 1994; Hauger, et al, 1996). On the basis of this research, the committee voted to recommend the installation of detectable warnings at sidewalk/street transitions.*

*A few committee members did not fully support this recommendation, feeling there might be a significant adverse impact on safety and ease of travel for wheelchair users. The committee discussed threshold ramp grade requirements where only the gentlest ramps (1:15 and flatter) would have detectable warnings. Nonetheless, because such a requirement would tend to confuse both designers and builders and would give inconsistent information to individuals who are visually impaired, the committee voted to require detectable warnings on all sidewalk/street transitions regardless of slope.*

**(B) Location.** The detectable warning shall be located so that the edge nearest the curb line or other potential hazard is 6 to 8 inches (150 to 205 mm) from the curb line or other potential hazard, such as a reflecting pool edge or the dynamic envelope of rail operations.

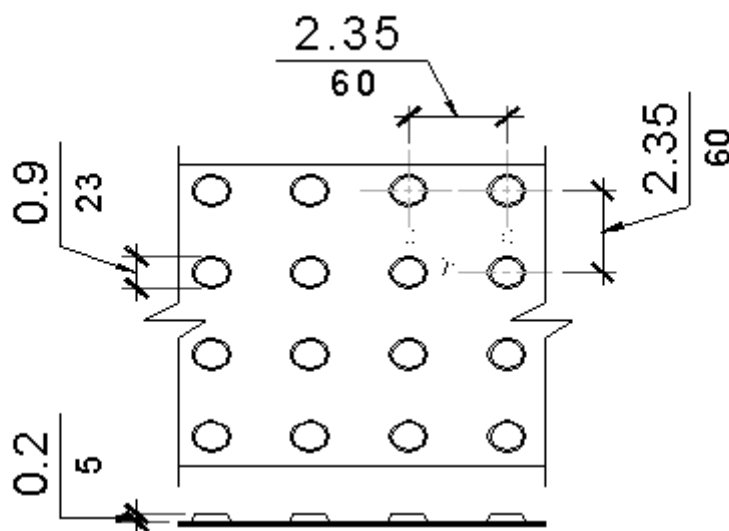
**Discussion:** Placement of the detectable warnings a maximum of 6 to 8 inches back from the curb line gives some latitude in placement of the detectable warning. Where curbing is embedded at the sidewalk/street junction, this will not need to be replaced. In addition, allowing 6 to 8 inches of ramp (or curb) surface beyond the detectable warning will give pedestrians who are blind an additional stopping distance before they step into the street. It will also enable some persons having mobility impairments to make a smoother transition between the street and the curb ramp.

**(C) Dome size and spacing.** Truncated domes shall have a diameter of 0.9 inch (23 mm) at the bottom, a diameter of 0.4 inch (10 mm) at the top, a height of 0.2 inch (5 mm) and a center-to-center spacing of 2.35 inches (60 mm) measured along one side of a square arrangement.



**Figure X02.5 N Dome Section**

Section of dome from a detectable warning. Drawing shows height, top and bottom dimensions.



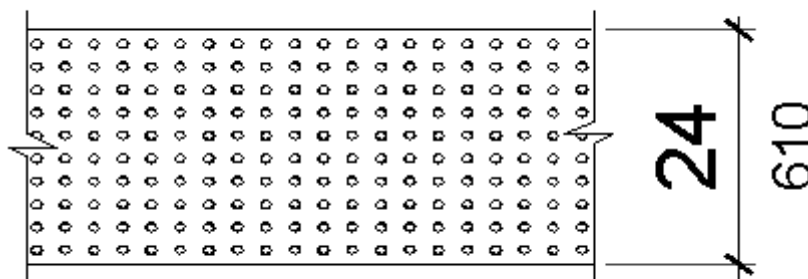
**Figure X02.5 O Dome Spacing**

Plan and section views of detectable warning domes and their relative spacing on the x and y axis.

**Discussion:** *The size and spacing of the domes affect detectability by pedestrians who are blind. This specification is much more detailed than that in the current ADAAG, and offers much less latitude in dimensions and spacing. It ensures that the dome spacing is the maximum currently known to be consistent with high detectability. The diameter measurement in the present ADAAG is ambiguous if the user of these guidelines is not told whether the diameter is to be measured at the bottom or the top of the truncated domes. As currently implemented by most U.S. manufacturers, it is the bottom diameter that measures 0.9 inch, and the top diameter varies widely. The diameter of the dome where it touches the sole of the shoe affects detectability, and the top diameter of 0.4 inch, in the suggested language, is based on current research (see below).*

*A few members of the committee felt that there needed to be more flexibility in the size and shape of the domes. Some suggestions were that the domes be a semi-spherical shape using a 1-inch base, or a "butte" design with a larger top diameter (0.6 inch). Wider spacing, up to 3 inches, between domes was also suggested. It was felt that the wider gaps or lanes between the domes would better accept the wheel path of most wheelchairs so that users would not need to "bump" over the domes. However, there was no evidence that either of these alternatives would be better or worse than the proposed standard in terms of ease of traversal by wheelchair users and detectability for individuals who are blind or visually impaired. The proposed standard is supported by research on spacing and detectability completed in Japan in 1998. The committee voted to recommend the parallel alignment of domes as well as the two-foot depth of the detectable warning, in consideration of minimizing bumpiness for wheelchair users.*

**(D) Dome alignment.** Domes shall be aligned on a square grid in the predominant direction of travel to permit wheels to roll between domes.



**Figure X02.5 P Dome Alignment**

Plan view of a detectable warning surface showing domes aligned in rows, not skewed diagonally.

**Discussion:** *This specification ensures the greatest degree of safety and negotiability for persons with mobility impairments. It requires square alignment, to give persons using wheeled mobility aids the greatest chance of being able to avoid the truncated domes.*

**(E) Visual Contrast.** There shall be a minimum of 70 percent contrast in light reflectance between the detectable warning and an adjoining surface, or the detectable warning shall be “safety yellow”. The material used to provide visual contrast shall be an integral part of the detectable warning surface.

**Advisory:** *Both domes and the underlying surface must meet the contrast requirement. Visual contrast shall be measured in accordance with existing ADAAG, A4.2.9.2, appendix.*

**Discussion:** *For pedestrians with low vision, a visual contrast will provide information about the location of the detectable warning and the street edge. Safety yellow is a color that is standardized for use as a warning in the pedestrian/highway environment. It has been demonstrated to be highly detectable when used as a detectable warning in contrasts as low as 40 percent (Bentzen, B.L., Nolin, T.L. & Easton, R.D. (1994) Detectable warning surfaces: Color, contrast and reflectance. Final report, US Department of Transportation, Federal Transit Administration, Volpe National*

*Transportation Systems Center. VNTSC-DTRS 57093-P-80546.) ADAAG currently recommends a 70 percent contrast, dark-on-light or light-on-dark.*

*There was concern on the part of some members that it may be impossible to develop and maintain a minimum 70 percent visual contrast with the materials commonly used in construction of public street improvements, such as portland cement concrete. The committee agreed that visual contrast was essential but some members suggested that a lesser level of contrast could be as effective and more economical to provide than a minimum 70%.*

*Some members of the committee noted that safety yellow is not conspicuous to many persons with low vision, and that therefore high visual contrast should be the sole measure of whether detectable warnings are visible.*

**Research need:** *The committee encourages the transportation industry to broaden its testing of color and contrast of typical construction materials and to include pedestrians with vision impairments in the development of standards. Work performed at The Lighthouse in New York City and research by Bentzen et al. (1994) can provide a useful basis for future research.*

## **X02.5.8 Pedestrian overpasses and underpasses.**

**X02.5.8.1 General.** Where pedestrian overpasses and underpasses are provided to cross public rights-of-way, each shall meet the requirements set forth in this section.

**X02.5.8.2 Pedestrian access route.** Where pedestrian overpasses and underpasses are provided as a primary means to cross a street, they must have continuous pedestrian access routes and shall provide an accessible connection to adjacent pedestrian facilities. When the continuous pedestrian access route of an overpass or underpass requires a ramp (i.e. with a grade greater than 1:20) and the vertical rise is greater than five feet, an elevator complying with proposed ADAAG §407.2 is required.

**X02.5.8.3 Stairs.** Stairs, when provided, shall comply with proposed ADAAG §504.

**X02.5.8.4 Signs.** Signs, where provided, shall be both tactile and visual and shall comply with proposed ADAAG §703.2.

**X02.5.8.5 Lighting.** Reserved.

**Advisory:** *When artificial lighting is used to illuminate a pedestrian underpass, variable level lighting should be considered to maximize accessibility for persons with low vision. The difference between external lighting conditions and those in the overpass or*

# Detectable Warnings: Synthesis of U.S. and International Practice

Work performed under contract by:

Billie Louise Bentzen, Ph.D.

Janet M. Barlow, COMS

Lee S. Tabor, architect

**Accessible Design for the Blind**

P.O. Box 1212

Berlin, Massachusetts 01503 USA

978-838-2307 voice / fax

bbentzen@ma.ultranet.com

12 May 2000



U.S. Access Board • 1331 F Street, NW • Suite 1000 • Washington, DC 20004-1111  
(800) 872-2253 (Voice) • (800) 993-2822 (TTY) • (202) 272-5447 (Fax)  
info@access-board.gov (E-mail) • <http://www.access-board.gov> (Website)

## Definition & specification

---

### Definition of detectable warnings

A detectable warning is:

**A standardized surface feature built in or applied to walking surfaces or other elements to warn visually impaired people of hazards on a circulation path. ADAAG 3.5**

Detectable warnings are unique and standardized features, intended to function much like a stop sign. They alert pedestrians who are visually impaired to the presence of hazards in the line of travel, indicating that they should stop and determine the nature of the hazard before proceeding further.

---

### Specification for detectable warnings

ADAAG specifies:

**Detectable warnings shall consist of raised truncated domes with a diameter of nominal 0.9 in (23 mm), a height of nominal 0.2 in (5 mm) and a center-to-center spacing of nominal 2.35 in (60 mm) and shall contrast visually with adjoining surfaces, either light-on-dark or dark-on-light.**

**The material used to provide contrast shall be an integral part of the walking surface. Detectable warnings used on interior surfaces shall differ from adjoining walking surfaces in resiliency or sound-on-cane contact. ADAAG 4.29.2**

---

### Visual contrast

The appendix to ADAAG recommends that detectable warnings contrast visually with adjoining surfaces.

**The material used to provide contrast should contrast by at least 70%. Contrast in percent is determined by:**

$$\text{Contrast} = [(B_1 - B_2)/B_1] \times 100$$

**where  $B_1$  = light reflectance value (LRV) of the lighter area and  $B_2$  = light reflectance value (LRV) of the darker area.**

**Note that in any application both white and black are never absolute: thus,  $B_1$  never equals 100 and  $B_2$ , is always greater than 0. ADAAG A4.29**

---

# Geometry of detectable warnings

## Dome alignment & pattern

The detectable warning surface consists of truncated domes on a square pattern which are typically arranged in either of two configurations:

- Diagonal alignment
- Parallel alignment

Figure 2-1 illustrates how both configurations can comply with the ADAAG specification for detectable warning.

Depending on which configuration is used, the rows of domes will be aligned with, or at a 45° angle to:

- the curb or platform edge
- the direction of travel

Pedestrians encountering either configuration will find the surface pattern equally detectable.

Another acceptable and plausible arrangement of truncated domes uses an equilateral triangular grid. Only one U.S. manufacturer has ever chosen to produce a detectable warning surface using this pattern.

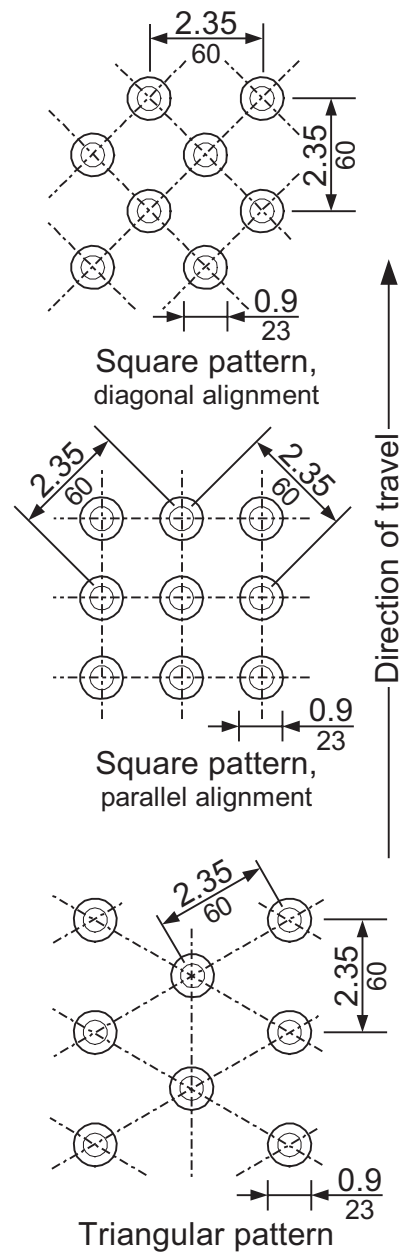
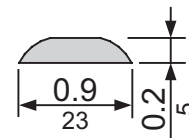


FIG. 2-1. PATTERNS AND ALIGNMENTS OF TRUNCATED DOMES COMPRISING THE ADAAG DETECTABLE WARNING.

## Dome profile

FIG. 2-2. HEIGHT AND DIAMETER OF TRUNCATED DOMES USED IN ADAAG DETECTABLE WARNING.



## Research on visual contrast

---

### **Contrast of detectable warnings**

ADAAG 4.29.2 requires that detectable warnings contrast visually with adjoining surfaces, either dark on light, or light on dark. A 70% contrast in light reflectance between a detectable warning and an adjoining surface is recommended in the Appendix (A4.29.2).

---

### **Research shows value of safety yellow**

Recent research indicates that the color safety yellow is so salient—even to persons having very low vision—that it is highly visible even when used in association with surfaces having light reflectance values differing by as little as 40% (new, gray-white concrete) (Bentzen, Nolin, and Easton, 1994a).

- A safety yellow detectable warning surface having a 40% reflectance difference from new concrete was subjectively judged more detectable than a darker warning surface which contrasted with new concrete by 86% (Bentzen et al., 1994a).
  - Hughes (1995) found that yellow or yellow-orange warning surfaces were preferred over black warning surfaces.
- 

### **Standards for safety yellow**

Safety yellow is a color that is standardized for use as a warning in the pedestrian/highway environment.

- U.S. —ANSI Z535.1-1991, 6.3
  - Internationally—ISO 3864-1984(E)
-

## Detectable Warning Surfaces

### What is a detectable warning

A detectable warning is “A standardized surface feature built in or applied to walking surfaces or other elements to warn of hazards on a circulation path.” (F106.5, Draft Final ADA and ABA Accessibility Guidelines, April 2, 2002) It is a unique and standardized feature, intended to function much like a stop sign and to alert pedestrians who are visually impaired to the presence of a hazard in the line of travel.



### Why is it necessary

As curb ramps have become common in response to the requirements of the Rehabilitation Act (1973) and the Americans with Disabilities Act (1990), an unintended consequence has been that blind pedestrians have found it more difficult to locate the boundary between the street and sidewalk. The only surface which has repeatedly been demonstrated to be detectable to most blind pedestrians, either under foot or by the use of a long cane, is the truncated dome detectable warning surface, which has been required on transit platform edges since 1991 and at curb ramps since July 2001.

### Specifications

“Detectable warnings shall consist of a surface of truncated domes aligned in a square grid pattern...”

“Dome size. Truncated domes in a detectable warning surface shall have a base diameter of 0.9 in (23 mm) minimum to 1.4 inches (36mm) maximum, a top diameter of 50% of the base diameter minimum to 65% of the base diameter maximum, and a height of 0.2 in (5 mm).

Dome Spacing. Truncated domes in a detectable warning surface shall have a center-to-center spacing of 1.6 inches (41 mm) minimum and 2.4 inches (61mm) maximum and a base-to-base spacing of 0.65 inches (16mm) minimum, measured between the most adjacent domes on square grid.

Contrast. Detectable warning surfaces shall contrast visually with adjoining surfaces, either light-on-dark or dark-on-light.” (Draft Guidelines for Accessible Public Rights-of-Way, June 14, 2002)

## Research

Two research projects (Barlow and Bentzen, 1992, and Hauger, Safewright, Rigby & McAuley, 1994) confirmed that, for blind travelers, removal of the single most reliable cue to the presence of an intersecting street, that is, the down curb, caused problems. At curb ramps, even skilled travelers failed to detect the street before stepping into it on 39% of approaches. The failure to detect streets was highly correlated with slope of the curb ramp and with the abruptness of change in angle between the approaching sidewalk and the curb ramp. Hauger et al. also found that diagonal/ apex curb ramps were more likely to lead to unsuccessful street crossings.

Despite concerns that detectable warnings would negatively affect the travel of mobility impaired individuals, Bentzen et al. 1993; Bentzen et al. 1994, Hauger et al., 1994, and Hauger et al. 1996 found that truncated dome detectable warnings on slopes or curb ramps had little effect on safety and negotiability for persons having mobility impairments. In fact, Hauger et al. found that persons with mobility impairments generally considered curb ramps having detectable warnings to be safer, more slip resistant, more stable, and to require less effort to negotiate than concrete curb ramps. Both teams of investigators found, however, that a small minority of persons having mobility impairments experienced some difficulty as a result of detectable warnings.

## Recommendations

ADAAG originally required the detectable warning surface on the entire width and depth of curb ramps, excluding the flare. To minimize the possibility of problems for persons with mobility impairments and to provide consistent information about the location of the street to individuals who are blind, Bentzen and Barlow (1995) concluded by recommending that 24 in (610 mm) of truncated dome detectable warning be installed along the bottom of curb ramps. That amount had previously been demonstrated to be sufficient to enable detection and stopping on most approaches and was consistent with the depth of detectable warning used at the edges of transit platforms having a drop-off.

It is the current recommendation of American Council of the Blind and of the Association for the Education and Rehabilitation of the Blind and Visually Impaired and is consistent with the ADAAG requirement for truncated dome detectable warning at transit platforms. This is also the recommendation of the Public Rights-of-Way Access Advisory Committee (PROWAAC, Access Board, 2001).

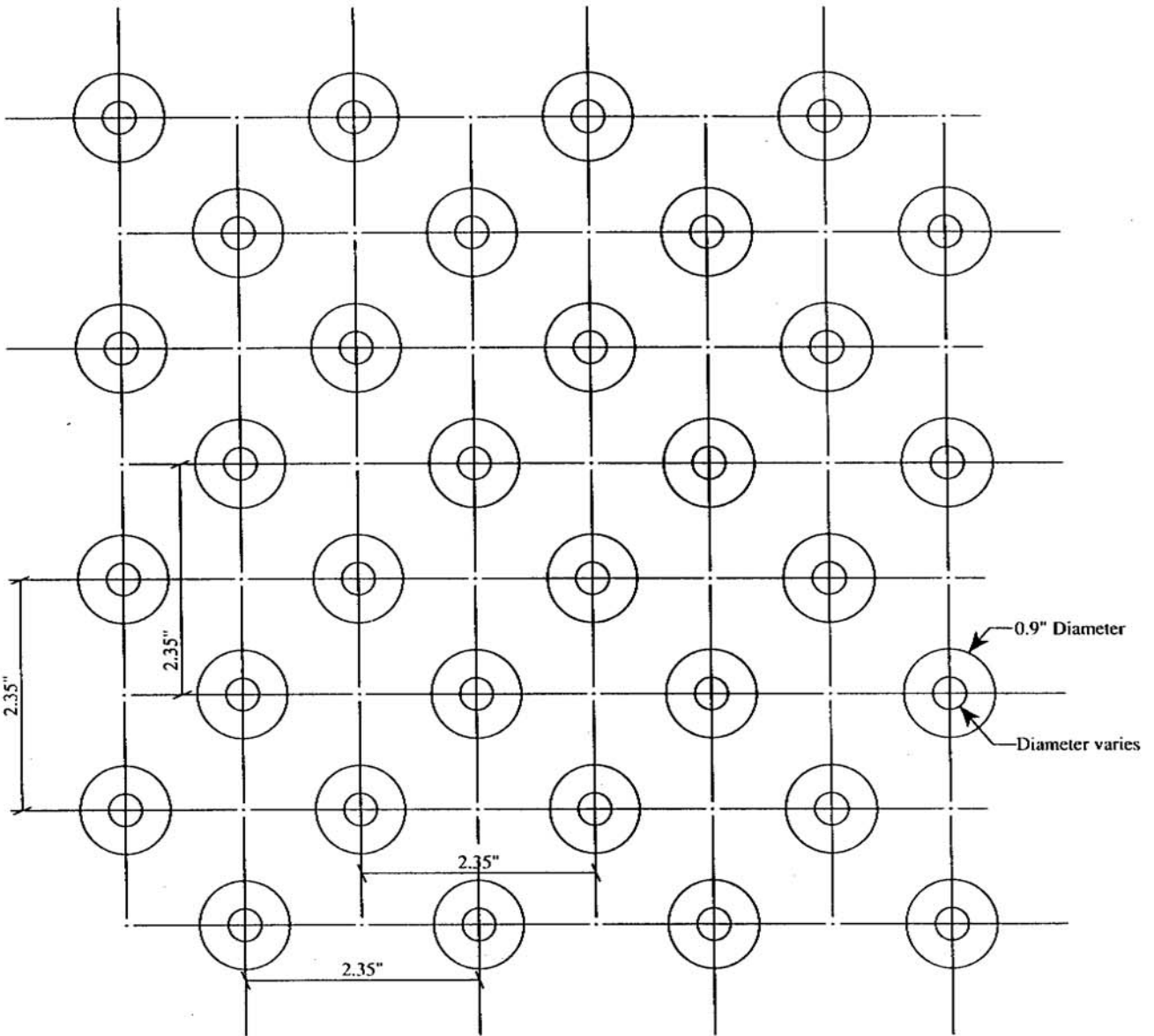
There are now a number of truncated dome products available for installation on curb ramps in various climates and conditions. A report on detectable warnings has been developed by the Access Board and is available by calling 800-872-2253 and asking for Detectable Warnings: Synthesis of U.S. and International Practice. The publication is also available on-line at [www.access-board.gov](http://www.access-board.gov).

## SURVEY FORM 21: DETECTABLE WARNINGS

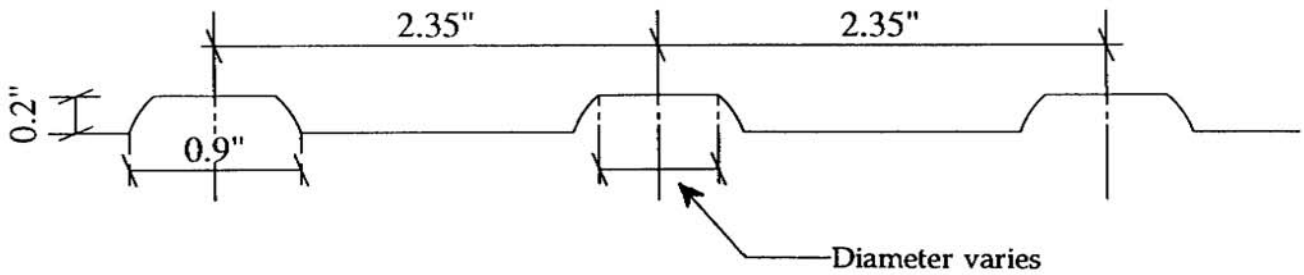
Use with the Minimum Requirements Summary Sheets and ADAAG.

Facility Name:	See Minimum Requirements Summary Sheets I and J for special requirements and exceptions which may be allowed in alterations and historic preservation. See also ADAAG 4.1.6 and 4.1.7.
<b>Location of Detectable Warning:</b>	

Section	Item	Technical Requirements	Comments	Yes	No
4.7.7	Curb Ramps:	Do curb ramps on a site have a detectable warning complying with 4.29.2 (see below) extending the full width and depth of the curb ramp? (Detectable warnings are not required on the flared sides.)			
4.29.5	Hazardous Vehicular Way:	If a walk crosses or adjoins a vehicular way and the walking surfaces are not separated by curbs, railings, or other elements between the pedestrian areas and vehicular areas, is the boundary between the areas defined by a continuous detectable warning complying with 4.29.2 which is 36 inches wide on the edge of the pedestrian area?			
4.29.6	Reflecting Pools:	Are the edges of reflecting pools protected by railings, walls, curbs, or detectable warnings complying with 4.29.2?			
4.29.2	Detectable Warnings - Pattern:	Do detectable warnings consist of raised truncated domes with a nominal diameter of 0.9 inches, a nominal height of 0.2 inches, and a nominal center-to-center spacing of 2.35 inches? (See Figure below)			
	Contrast:	Do detectable warnings contrast visually with adjoining surfaces (light-on-dark or dark-on-light)?			
		Is the material used to provide contrast an integral part of the walking surface?			
	Interior Resilience and Sound:	Do the detectable warnings used on interior surfaces differ from adjoining walking surfaces in resiliency or sound-on-cane contact?			



**Detectable Warning: Pattern**



**Detectable Warning: Section**  
NTS